

# YASKAWA AC Drive 1000-Series Option Motor Encoder Feedback (EnDat, HIPERFACE) Interface Installation Manual

Type: PG-F3

To properly use the product, read this manual thoroughly and retain for easy reference, inspection, and maintenance. Ensure the end user receives this manual.

## 安川インバータ 1000シリーズオプション エンコーダインタフェース (EnDat, HIPERFACE用) 取扱説明書

形 式 PG-F3

製品を安全にお使い頂くために、本書を必ずお読みください。  
また、本書をお手元に保管していただくとともに、最終的に本製品をご使用になるユーザー様のお手元に確実に届けられるよう、お取り計らい願います。

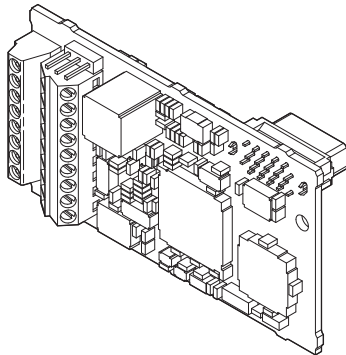

---

## **Copyright © 2009 YASKAWA ELECTRIC CORPORATION**

All rights reserved. No part of this publication may be reproduced, stored in a retrieval system, or transmitted, in any form or by any means, mechanical, electronic, photocopying, recording, or otherwise, without the prior written permission of Yaskawa. No patent liability is assumed with respect to the use of the information contained herein. Moreover, because Yaskawa is constantly striving to improve its high-quality products, the information contained in this manual is subject to change without notice. Every precaution has been taken in the preparation of this manual. Yaskawa assumes no responsibility for errors or omissions. Neither is any liability assumed for damages resulting from the use of the information contained in this publication.

# Table of Contents

---

<b>1 PREFACE AND SAFETY .....</b>	<b>4</b>
<b>2 PRODUCT OVERVIEW .....</b>	<b>8</b>
<b>3 RECEIVING .....</b>	<b>9</b>
<b>4 OPTION COMPONENTS .....</b>	<b>10</b>
<b>5 INSTALLATION PROCEDURE .....</b>	<b>11</b>
<b>6 RELATED PARAMETERS .....</b>	<b>32</b>
<b>7 TROUBLESHOOTING .....</b>	<b>35</b>
<b>8 SPECIFICATIONS .....</b>	<b>43</b>

## 1 Preface and Safety

Yaskawa manufactures products used as components in a wide variety of industrial systems and equipment. The selection and application of Yaskawa products remain the responsibility of the equipment manufacturer or end user. Yaskawa accepts no responsibility for the way its products are incorporated into the final system design. Under no circumstances should any Yaskawa product be incorporated into any product or design as the exclusive or sole safety control. Without exception, all controls should be designed to detect faults dynamically and fail safely under all circumstances. All systems or equipment designed to incorporate a product manufactured by Yaskawa must be supplied to the end user with appropriate warnings and instructions as to the safe use and operation of that part. Any warnings provided by Yaskawa must be promptly provided to the end user. Yaskawa offers an express warranty only as to the quality of its products in conforming to standards and specifications published in the Yaskawa manual. **NO OTHER WARRANTY, EXPRESS OR IMPLIED, IS OFFERED.** Yaskawa assumes no liability for any personal injury, property damage, losses, or claims arising from misapplication of its products.

### ◆ Applicable Documentation

The following manuals are available for the option:

#### Option

	<b>Yaskawa AC Drive 1000-Series Option Motor Encoder Feedback (EnDat/HIPERFACE) Interface PG-F3 Installation Manual (This book)</b> <b>Manual No: TOBPC73060051</b>	Read this manual first. The installation manual is packaged with the option and contains information required to install the option and set up related drive parameters.
--	--	--

#### Yaskawa Drive

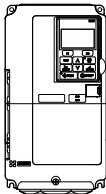
	<b>Yaskawa AC Drive 1000-Series Quick Start Guide</b>  <b>Yaskawa AC Drive 1000-Series Technical Manual</b>	The drive manuals cover basic installation, wiring, operation procedures, functions, troubleshooting, and maintenance information. The manuals also include important information about parameter settings and drive tuning. Access these sites to obtain Yaskawa instruction manuals: U.S.: <a href="http://www.yaskawa.com">http://www.yaskawa.com</a> Europe: <a href="http://www.yaskawa.eu.com">http://www.yaskawa.eu.com</a> Japan: <a href="http://www.e-mechatronics.com">http://www.e-mechatronics.com</a> For questions, contact your local Yaskawa sales office or the nearest Yaskawa representative.
--	---	---

## ◆ Terms and Abbreviations

<b>Note:</b>	Indicates supplemental information that is not related to safety messages
<b>Drive:</b>	Yaskawa AC Drive 1000-Series
<b>Option:</b>	Yaskawa AC Drive 1000-Series Option Motor Encoder Feedback (EnDat/HIPERFACE) Interface: Type PG-F3
<b>PG:</b>	Pulse Generator or Encoder mounted on the motor
<b>V/f:</b>	V/f Control
<b>V/f w/PG:</b>	V/f Control with PG
<b>CLV:</b>	Closed Loop Vector Control
<b>AOLV/PM:</b>	Advanced Open Loop Vector Control for PM
<b>CLV/PM:</b>	Closed Loop Vector Control for PM

---

## ◆ Registered Trademarks

- EnDat is a trademark of DR. JOHANNES HEIDENHAIN GmbH.
- HIPERFACE is a trademark of SICK STEGMANN GmbH & Co., KG.

Trademarks are the property of their respective owners.

# 1 Preface and Safety

---

## ◆ Supplemental Safety Information

Read and understand this manual before installing, operating, or servicing this option. Install the option according to this manual and local codes.

The following conventions indicate safety messages in this manual. Failure to heed these messages could cause fatal injury or damage products and related equipment and systems.

### **DANGER**

Indicates a hazardous situation, which, if not avoided, will result in death or serious injury.

### **WARNING**

Indicates a hazardous situation, which, if not avoided, could result in death or serious injury.

### **CAUTION**

Indicates a hazardous situation, which, if not avoided, could result in minor or moderate injury.

### **NOTICE**

Indicates an equipment damage message.

## ■ General Safety

### General Precautions

- The diagrams in this book may include options and drives without covers or safety shields to illustrate details. Be sure to reinstall covers or shields before operating any devices. Use the option according to the instructions described in this manual.
- Any illustrations, photographs, or examples used in this manual are provided as examples only and may not apply to all products to which this manual is applicable.
- The products and specifications described in this manual or the content and presentation of the manual may be changed without notice to improve the product and/or the manual.
- When ordering new copies of the manual, contact a Yaskawa representative or the nearest Yaskawa sales office and provide the manual number shown on the front cover.

### DANGER

#### **Heed the safety messages in this manual.**

Failure to comply will result in death or serious injury.

The operating company is responsible for any injuries or equipment damage resulting from failure to heed the warnings in this manual.

### NOTICE

#### **Do not modify the drive or option circuitry.**

Failure to comply could result in damage to the drive or option and will void warranty. Yaskawa is not responsible for any modification of the product made by the user. This product must not be modified.

#### **Do not expose the drive or option to halogen group disinfectants.**

Failure to comply may cause damage to the electrical components in the option.

Do not pack the drive in wooden materials that have been fumigated or sterilized.

Do not sterilize the entire package after the product is packed.

# 2 Product Overview

### ◆ About This Product

The PG-F3 Option allows the user to connect certain rotary encoders to applicable Yaskawa drives. Suitable rotary encoders include either EnDat 2.1/01, EnDat 2.2/01, or EnDat 2.2/22 by HEIDENHAIN, or HIPERFACE by SICK STEGMANN.

The PG-F3 Option facilitates motor speed feedback to the drive and takes advantage of Closed Loop Vector control for PM Motors. The option increases control accuracy and performance.

An encoder signal allows the drive to compensate for subtle variations in the load, while providing the drive with the necessary data to control the output frequency and maintain an accurate constant speed.

The PG-F3 Option reads a maximum input frequency from the encoder of 20 kHz when using EnDat 2.1/01, EnDat 2.2/01, or HIPERFACE. Be sure to select an encoder with an output of maximum of 20 kHz when operating at maximum speed.

The maximum input frequency is not a concern when using EnDat 2.2/22 because compatible encoder models utilize serial communication.

Set the drive motor control mode to operate in the Closed Loop Vector Control for PM Motors when using the PG-F3 Option. Refer to the drive Technical Manual for details.

### ◆ Applicable Models

The option can be used with the drive models in [Table 1](#).

**Table 1 Applicable Models**

Drive Series	Drive Model Number
A1000	All models <1>
L1000A	All models <2>

<1> Only available in software version S1018 and later. The software version (PRG) is indicated on the nameplate affixed to the side of the drive.

<2> EnDat 2.2/22 and HIPERFACE are available in drive software PRG:7016 and later.





## 3 Receiving

Please perform the following tasks upon receiving the option:

- Inspect the option for damage. Contact the shipper immediately if the option appears damaged upon receipt.
- Verify receipt of the correct model by checking the model number printed on the option nameplate (Refer to *Figure 1* on page 10 for more information).
- Contact your supplier if you have received the wrong model or the option does not function properly.

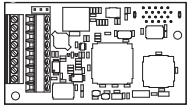
### ◆ Option Package Contents

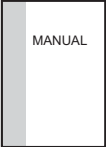
Description:	Option	Ground Wire	Screws (M3)	Installation Manual
				
Quantity:	1	1	3	1

### ◆ Tools Required for Installation

- A Phillips screwdriver (M3 metric / #1, #2 U.S. standard size) is required to install the option.
- A flat-blade screwdriver (blade depth: 0.4 mm, width: 2.5 mm) is required to wire the option terminal block.
- A pair of diagonal cutting pliers.
- A small file or medium-grit sandpaper.

**Note:** Tools required to prepare option cables for wiring are not listed in this manual.

# 4 Option Components

### ◆ PG-F3 Option

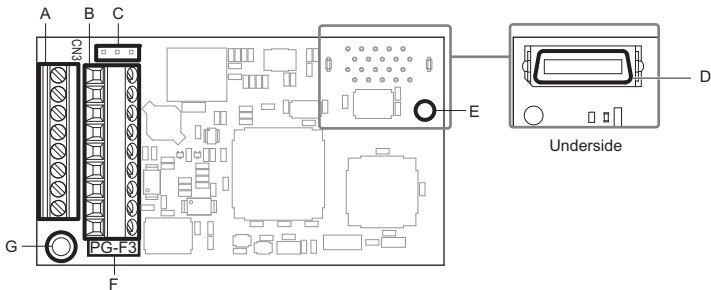

**A** – Terminal block TB1

**B** – Terminal block TB2

**C** – Jumper for PG encoder power supply voltage (CN3) <1>

**D** – Connector (CN5)

**E** – Installation hole

**F** – Model number

**G** – Ground terminal and installation hole <2>

<1> Refer to [Table 5](#) on page [24](#) for details.

<2> The ground wires provided in the option shipping package must be connected during installation.

**Figure 1 PG-F3 Option Components**

### ◆ Terminal Blocks TB1 and TB2

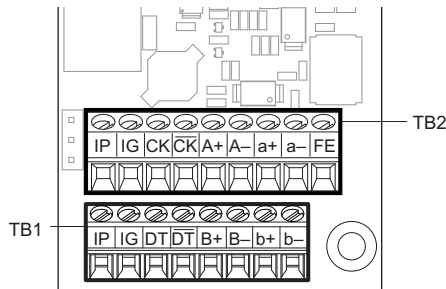

Refer to [Table 8](#) and [Table 9](#) on page [29](#) for details on TB1 and TB2 terminal functions and signal levels.

## 5 Installation Procedure

### ◆ Section Safety

#### DANGER

##### **Electric Shock Hazard**

**Do not connect or disconnect wiring while the power is on.**

Failure to comply will result in death or serious injury.

Disconnect all power to the drive, wait at least the amount of time specified on the drive front cover safety label. After all indicators are off, measure the DC bus voltage to confirm safe level, and check for unsafe voltages before servicing. The internal capacitor remains charged after the power supply is turned off.

#### WARNING

##### **Electrical Shock Hazard**

**Do not remove the front covers of the drive while the power is on.**

Failure to comply could result in death or serious injury.

The diagrams in this section may include options and drives without covers or safety shields to show details. Be sure to reinstall covers or shields before operating any devices. Use the option according to the instructions described in this manual.

**Do not allow unqualified personnel to use equipment.**

Failure to comply could result in death or serious injury.

Maintenance, inspection, and replacement of parts must be performed only by authorized personnel familiar with installation, adjustment, and maintenance of this product.

**Do not touch circuit boards while the power to the drive is on.**

Failure to comply could result in death or serious injury.

## 5 Installation Procedure

---

### **WARNING**

**Do not use damaged wires, stress the wiring, or damage the wire insulation.**

Failure to comply could result in death or serious injury.

#### **Fire Hazard**

**Tighten all terminal screws to the specified tightening torque.**

Loose electrical connections could result in death or serious injury by fire due to overheating of electrical connections.

### **NOTICE**

#### **Damage to Equipment**

**Observe proper electrostatic discharge (ESD) procedures when handling the option, drive, and circuit boards.**

Failure to comply may result in ESD damage to circuitry.

**Never shut the power off while the drive is running or outputting voltage.**

Failure to comply may cause the application to operate incorrectly or damage the drive.

**Do not operate damaged equipment.**

Failure to comply may cause further damage to the equipment.

Do not connect or operate any equipment with visible damage or missing parts.

**Tighten all terminal screws to the specified tightening torque.**

Failure to comply could result in damage to the terminal block.

**Do not use unshielded cable for control wiring.**

Failure to comply may cause electrical interference resulting in poor system performance.

Use shielded twisted-pair wires and ground the shield to the ground terminal of the drive.

### NOTICE

**Properly connect all pins and connectors.**

Failure to comply may prevent proper operation and possibly damage equipment.

**Check wiring to ensure that all connections are correct after installing the option and connecting any other devices.**

Failure to comply may result in damage to the option.

## 5 Installation Procedure

### ◆ Prior to Installing the Option

Prior to installing the option, wire the drive, make the necessary connections to the drive terminals, and verify that the drive functions normally. Refer to the Quick Start Guide packaged with the drive for information on wiring and connecting the drive.

*Figure 2* shows an exploded view of the drive with the option and related components for reference.

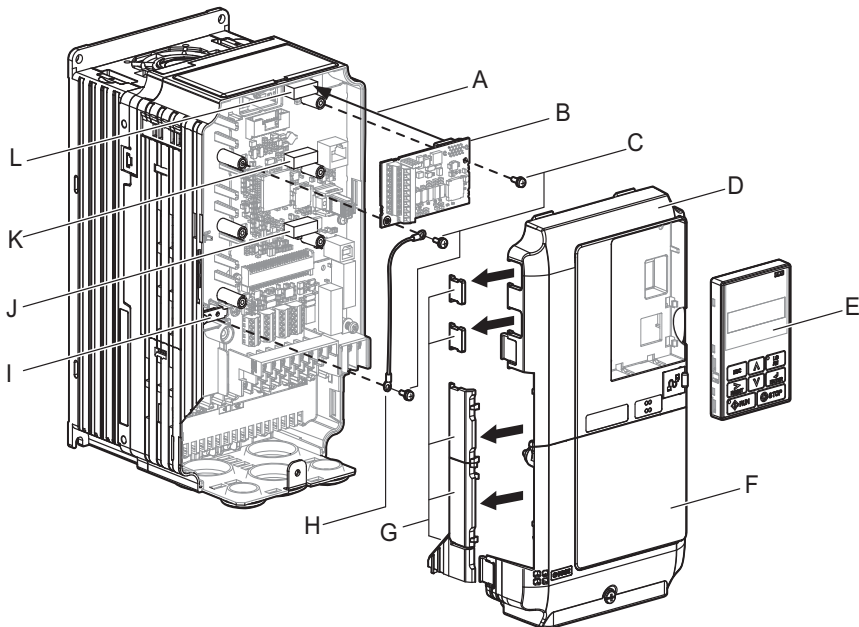

A – Insertion point for CN5

B – Option card

C – Included screws

D – Front cover

E – Digital operator

F – Terminal cover

G – Removable tabs for wire routing

H – Ground wire

I – Drive grounding terminal (FE)

J – Connector CN5-A

K – Connector CN5-B

L – Connector CN5-C

Figure 2 Drive Components with Option

### ◆ Installing the Option

Refer to the instructions below to install the option.

1. Shut off power to the drive, wait the appropriate amount of time for voltage to dissipate, then remove the digital operator (E), front cover (D), and terminal cover (F). Refer to the Quick Start Guide packaged with the drive.

**DANGER!** *Electrical Shock Hazard. Disconnect all power to the drive and wait at least the amount of time specified on the drive front cover safety label. After all indicators are off, measure the DC bus voltage to confirm safe level, and check for unsafe voltages before servicing to prevent electric shock. The internal capacitor remains charged even after the power supply is turned off.*

**NOTICE:** *Damage to Equipment. Observe proper electrostatic discharge procedures (ESD) when handling the option, drive, and circuit boards. Failure to comply may result in ESD damage to circuitry.*

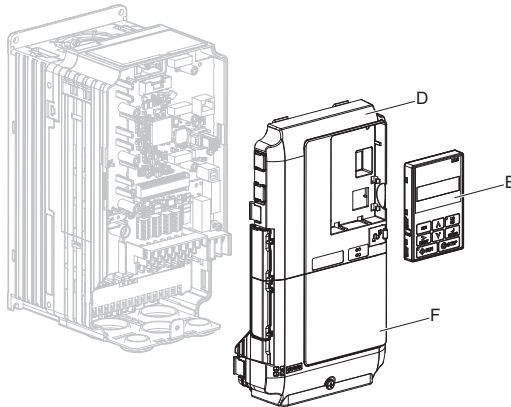

Figure 3 Remove the Front Cover, Terminal Cover, and Digital Operator

## 5 Installation Procedure

---

2. Insert the option card (B) into the CN5-C (L) connector located on the drive and fasten it into place using one of the included screws (C).

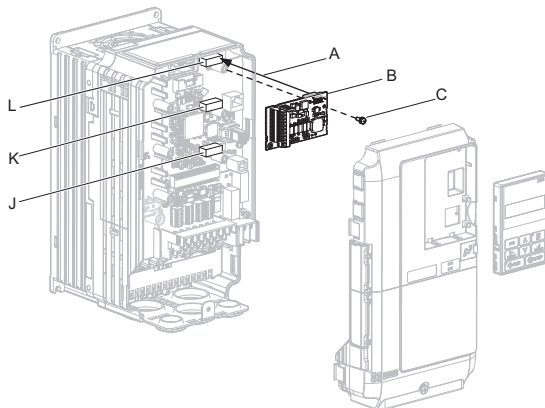
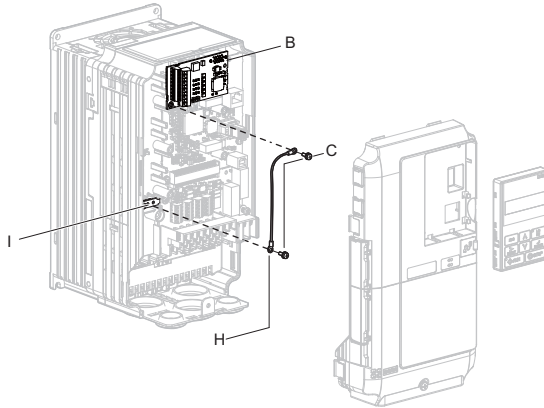

Figure 4 Insert the Option Card



3. Connect the ground wire (H) to the ground terminal (I) using one of the remaining screws (C). Connect the other end of the ground wire (H) to the remaining ground terminal and installation hole on the option (B) using the last remaining provided screw (C).



**Figure 5 Connect the Ground Wire**

**Note:** There are two screw holes on the drive for use as ground terminals (I). When connecting three options, two ground wires will need to share the same drive ground terminal.

## 5 Installation Procedure

4. Prepare and connect the wire ends as shown in [Figure 6](#) and [Figure 7](#). Refer to [Wire Gauges and Tightening Torques on page 28](#) to confirm that the proper tightening torque is applied to each terminal. Take particular precaution to ensure that each wire is properly connected and wire insulation is not accidentally pinched into electrical terminals.

**WARNING! Fire Hazard.** Tighten all terminal screws according to the specified tightening torque. Loose electrical connections could result in death or serious injury by fire due to overheating electrical connections. Tightening screws beyond the specified tightening torque may result in erroneous operation, damage the terminal block, or cause a fire.

**NOTICE:** Heat shrink tubing or electrical tape may be required to ensure that cable shielding does not contact other wiring. Insufficient insulation may cause a short circuit and damage the option or drive.

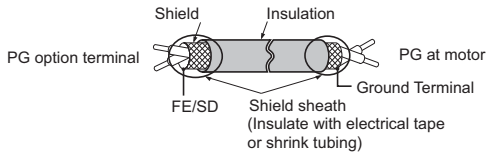

Figure 6 Preparing Ends of Shielded Cable

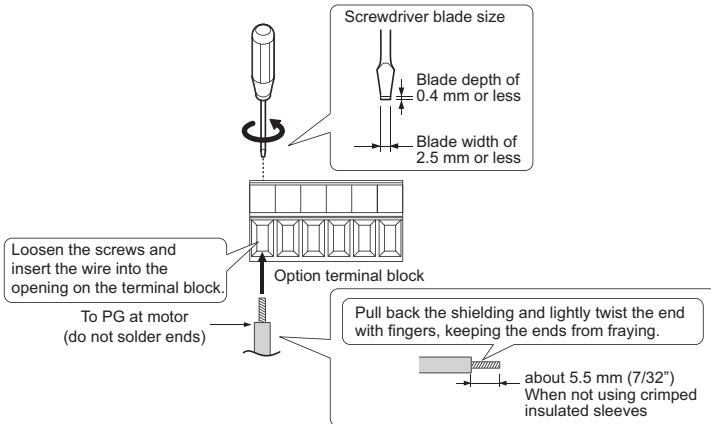

Figure 7 Preparing and Connecting Cable Wiring

### 5. Wire the motor PG encoder to the terminal block on the option.

- **Wiring EnDat 2.1/01 or EnDat 2.2/01 Encoders**

Wire the motor PG encoder to the terminal block on the option using a HEIDENHAIN 17-conductor cable. Refer to [Figure 6](#) and [Figure 7](#) for wiring instructions. Refer to [Figure 8](#) for the connection diagram.

The signal “Sensor Up” must be connected to terminal IP on the PG-F3 option for cables longer than 10 m. Additionally, the “Sensor 0 V” must be connected to terminal IG. Refer to [Table 8](#) and [Table 9](#) for a detailed description of the option terminal functions.

#### Connection Diagram

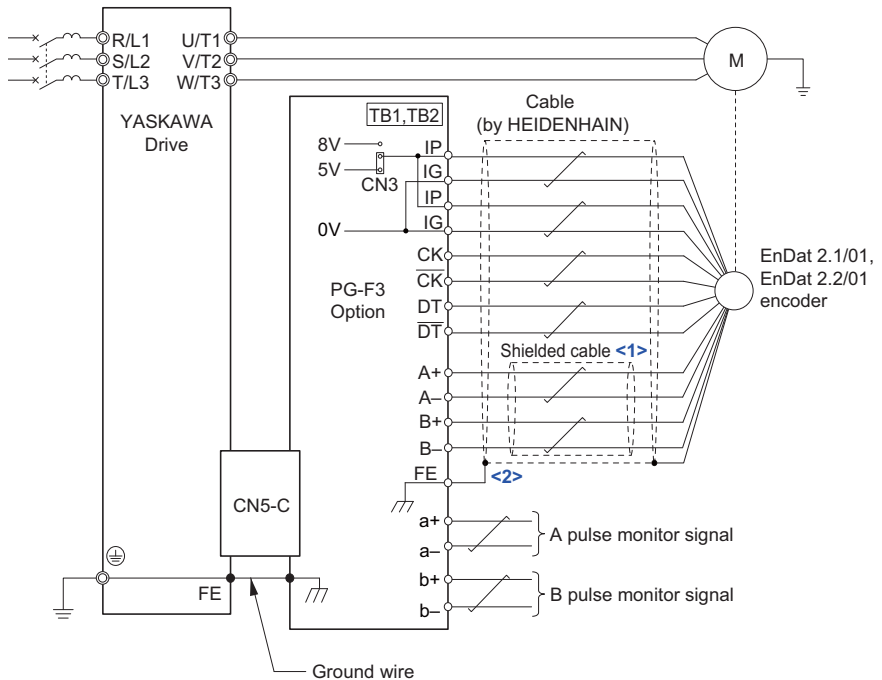

⊙ main circuit terminal    ○ control circuit terminal

<1> Properly connect the cable shield to terminal IG on the option Terminal Block TB2 or remove the ground connection on both ends.

<2> Ground the shield on the PG encoder side and the drive side. If noise problems arise in the PG encoder signal, remove the shield ground from one end of the signal line or remove the shield ground connection on both ends.

**Figure 8 PG-F3 Option and PG Encoder Connection Diagram (EnDat 2.1/01, EnDat 2.2/01)**

## 5 Installation Procedure

**Table 2 PG Encoder Cable Specification (EnDat 2.1/01, EnDat 2.2/01)**

Option Terminal	PG Encoder Cable	
	Color	PG Encoder Signal
IP	Brown/Green	Up
	Blue	Sensor Up
IG	White/Green	0V
	White	Sensor 0V
CK	Purple	CLOCK
$\overline{\text{CK}}$	Yellow	$\overline{\text{CLOCK}}$
DT	Gray	DATA
$\overline{\text{DT}}$	Pink	$\overline{\text{DATA}}$
A+	Green/Black	A+
A-	Yellow/Black	A-
B+	Blue/Black	B+
B-	Red/Black	B-

- **Wiring an EnDat 2.2/22 Encoder**

Wire the motor PG encoder to the terminal block on the option using a HEIDENHAIN 8-conductor cable. Refer to [Figure 6](#) and [Figure 7](#) for wiring instructions. Refer to [Figure 9](#) for the connection diagram.

The signal “Sensor Up” must be connected to terminal IP on the PG-F3 option for cables longer than 10 m. Additionally, the “Sensor 0 V” must be connected to terminal IG. Refer to [Option Terminal Functions \(EnDat\)](#) on page 29 for a detailed description of the option terminal functions.

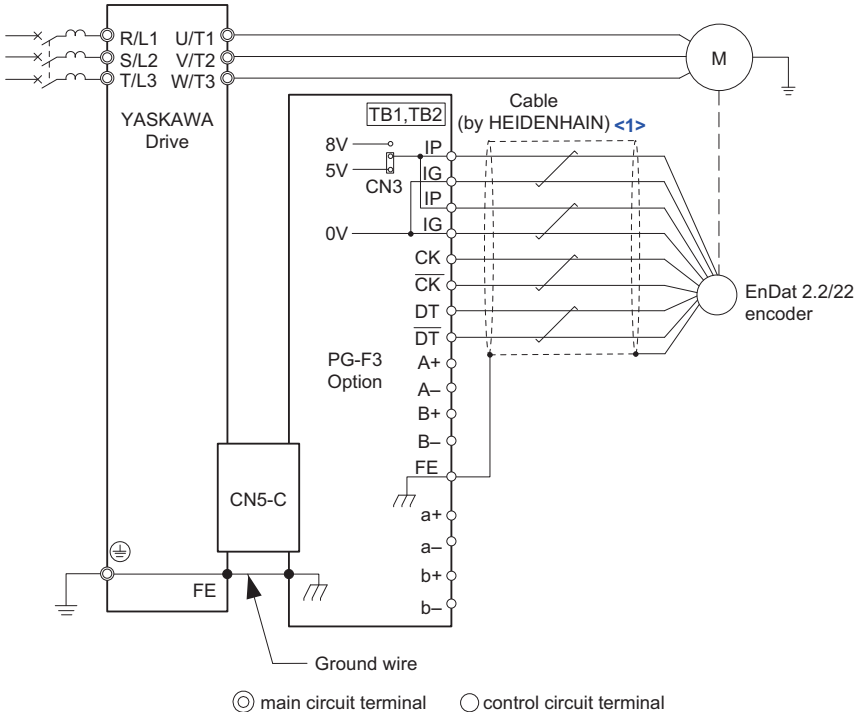

<1> Ground the shield on the PG encoder side and the drive side. If noise problems arise in the PG encoder signal, remove the shield ground from one end of the signal line or remove the shield ground connection on both ends.

**Figure 9 PG-F3 Option and PG Encoder Connection Diagram (EnDat 2.2/22)**

## 5 Installation Procedure

**Table 3 PG Encoder Cable Specification (EnDat 2.2/22)**

Option Terminal	PG Encoder Cable	
	Color	PG Encoder Signal
IP	Brown/Green	Up
	Blue	Sensor Up
IG	White/Green	0V
	White	Sensor 0V
CK	Purple	CLOCK
$\overline{CK}$	Yellow	$\overline{CLOCK}$
DT	Gray	DATA
$\overline{DT}$	Pink	$\overline{DATA}$
A+	–	–
A–	–	–
B+	–	–
B–	–	–

- **Wiring an HIPERFACE Encoder**

Wire the motor PG encoder to the terminal block on the option using a SICK STEGMANN 8-conductor cable. Refer to [Figure 6](#) and [Figure 7](#) for wiring instructions. Refer to [Figure 10](#) for the connection diagram.

[Refer to Option Terminal Functions \(EnDat\) on page 29](#) for a detailed description of the option terminal functions.

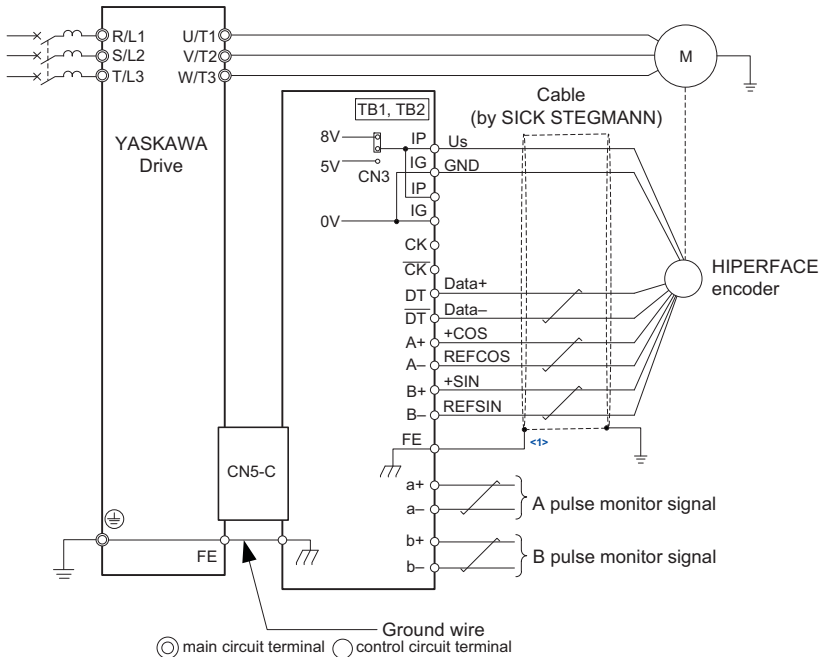

<1> Ground the shield on the PG encoder side and the drive side. If noise problems arise in the PG encoder signal, remove the shield ground from one end of the signal line or remove the shield ground connection on both ends.

**Figure 10 PG-F3 Option and PG Encoder Connection Diagram (HIPERFACE)**

## 5 Installation Procedure

**Table 4 PG Encoder Cable Specification (HIPERFACE)**

Option Terminal	PG Encoder Cable	
	Color	PG Encoder Signal
IP	Red	Us
IG	Blue	GND
CK	–	–
CK	–	–
DT	Gray/Yellow	DATA+
$\overline{DT}$	Green/Purple	DATA-
A+	Pink	+COS
A-	Black	REFCOS
B+	White	+SIN
$\overline{B}$	Brown	REFSIN

- 6.** Set the voltage for the PG encoder power supply using jumper CN3 located on the option. Position the jumper as shown in **Table 5** to select the voltage level.

**NOTICE:** The positioning of jumper CN3 selects the PG encoder power supply voltage (5 V or 8 V). Select the voltage level for the PG encoder connected to the option and motor. If the wrong voltage is selected, the PG encoder may not operate properly or may become damaged as a result.

**Table 5 Setting the PG Encoder Power Supply Voltage (IP) with Jumper CN3**

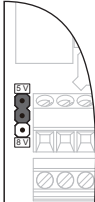
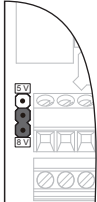
Voltage Level	5 V $\pm$ 5% (default)	8 V $\pm$ 10%
Jumper CN3 Position		



### 7. Route the option wiring.

Depending on the drive model, some drives may require routing the wiring through the side of the front cover to the outside. In these cases, cut out the perforated openings on the left side of the drive front cover as shown in **Figure 11-A** and leave no sharp edges to damage wiring.

Route the wiring inside the enclosure as shown in **Figure 11-B** for drives that do not require routing through the front cover.

Refer to the *Peripheral Devices & Options* section of the drive Technical Manual for more information.

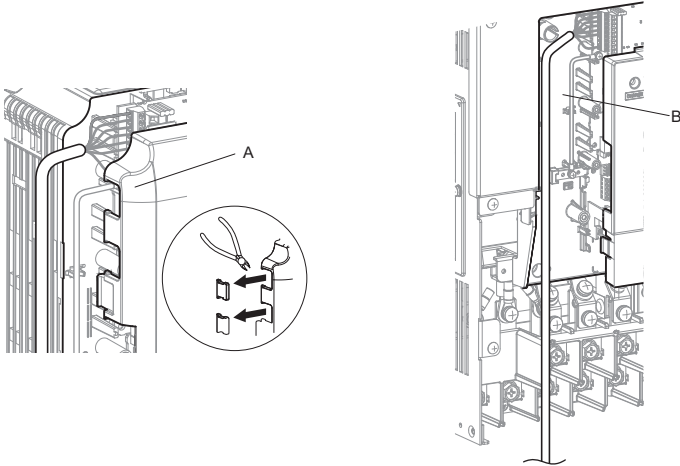

**A** – Route wires through the openings provided on the left side of the front cover. <1>

**B** – Use the open space provided inside the drive to route option wiring.

<1> The drive will not meet NEMA Type 1 requirements if wiring is exposed outside the enclosure.

**Figure 11 Wire Routing Examples**

## 5 Installation Procedure

---

8. Replace and secure the front covers of the drive (D, F) and replace the digital operator (E).

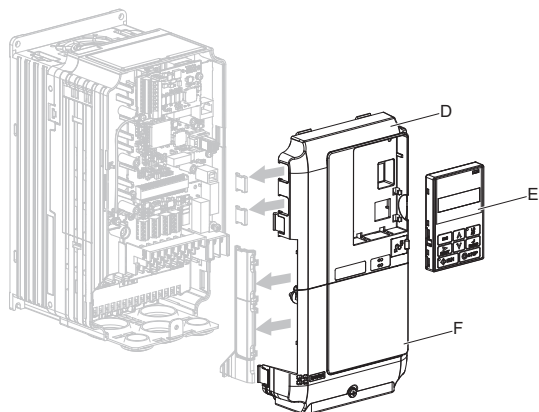
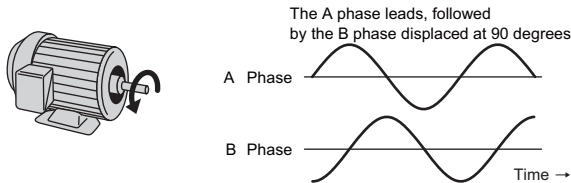

**Figure 12 Replace the Front Covers and Digital Operator**

**Note:** Take proper precautions when wiring the option so that the front covers will easily fit back onto the drive. Make sure cables are not pinched between the front covers and the drive when replacing the covers.

### 9. Set drive parameters in [Table 10](#) for proper motor rotation.

- Confirming Motor Rotation with EnDat 2.1/01, EnDat 2.2/01, or HIPERFACE**  
 The leading pulse determines the motor rotation direction. A PG encoder signal with leading A phase is considered to be rotating forward (counter-clockwise when viewing rotation from motor load side).



**Figure 13 Displacement of A and B Phases**

After connecting the PG encoder outputs to the option, apply power to the drive and manually rotate the motor and check the rotation direction by viewing monitor U1-05 on the digital operator.

**WARNING!** Ensure the drive RUN circuit is locked out and a RUN command is not possible before attempting to manually rotate the motor shaft with the drive powered on. Failure to comply may cause injury to personnel due to inadvertent equipment movement.

Reverse motor rotation is indicated by a negative value for U1-05; forward motor rotation is indicated by a positive value.

If monitor U1-05 indicates that the forward direction is opposite of what is intended, set drive parameter F1-05 to 1 to switch the direction of how the option reads pulses from the PG encoder output.

**Note:** If the drive is initialized using A1-03 = 1110, 2220, or 3330, the value for F1-05 will reset to the factory default and the parameter will need to be readjusted to switch the direction.

- Confirming Motor Rotation with EnDat 2.2/22**  
 EnDat 2.2/22 uses serial data transmission and lacks A and B phases, so it is necessary to refer to monitor U1-05 to determine the direction of rotation.  
 After connecting the PG encoder outputs to the option, apply power to the drive and manually rotate the motor and check the rotation direction by viewing monitor U1-05 on the digital operator.

**WARNING!** Ensure the drive RUN circuit is locked out and a RUN command is not possible before attempting to manually rotate the motor shaft with the drive powered on. Failure to comply may cause injury to personnel due to inadvertent equipment movement.

Reverse motor rotation is indicated by a negative value for U1-05; forward motor rotation is indicated by a positive value.

If the motor is rotating forward, but U1-05 reads that it is rotating in reverse, switch the rotation direction for the PG1 encoder by setting parameter F1-05 to 1.

**Note:** If the drive is initialized using A1-03 = 1110, 2220, or 3330, the value for F1-05 will reset to the factory default and the parameter will need to be readjusted to switch the direction.

## 5 Installation Procedure

### ◆ Wire Gauges, Tightening Torque, and Crimp Terminals

#### ■ Wire Gauges and Tightening Torques

Wire gauge and torque specifications are listed in [Table 6](#).

**Table 6 Wire Gauges and Tightening Torques**

Terminal Signal	Screw Size	Tightening Torque N·m (in·lb)	Bare Cable		Crimp Terminals		Wire Type
			Recomm. Gauge mm <sup>2</sup>	Applicable Gauges mm <sup>2</sup>	Applicable Gauges mm <sup>2</sup>	Recomm. Gauge mm <sup>2</sup>	
a+, a-, b+, b-, FE	M2	0.22 to 0.25 (1.95 to 2.21)	0.75 (18 AWG)	Stranded wire: 0.25 to 1.0 (24 to 17 AWG) Solid wire: 0.25 to 1.5 (24 to 16 AWG)	0.5 (20 AWG)	0.25 to 0.5 (24 to 20 AWG)	Shielded twisted pair, etc.
IP, IG, DT, DT, B+, B-, CK, CK, A+, A-			<I>	-	-	-	

<I> For EnDat 2.1/01 and EnDat 2.2/01, use a HEIDENHAIN 17-pin cable. Refer to [PG Encoder Cable Specification \(EnDat 2.1/01, EnDat 2.2/01\) on page 20](#) for details.

For EnDat 2.2/22, use a HEIDENHAIN 8-pin cable. Refer to [PG Encoder Cable Specification \(EnDat 2.2/22\) on page 22](#) for details.

For HIPERFACE, use a SICK STEGMANN 8-pin cable. Refer to [PG Encoder Cable Specification \(HIPERFACE\) on page 24](#) for details.

#### ■ Crimp Terminals

Yaskawa recommends using CRIMPFOX 6 by Phoenix Contact or equivalent crimp terminals with the specifications listed in [Table 7](#) for wiring to ensure proper connections.

**Note:** Properly trim wire ends so loose wire ends do not extend from the crimp terminals.

**Table 7 Crimp Terminal Sizes**

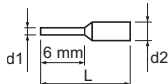
	Wire Gauge mm <sup>2</sup>	Phoenix Contact Model	L mm (in)	d1 mm (in)	d2 mm (in)
	0.25 (24 AWG)	AI 0.25 - 6YE	10.5 (13/32)	0.8 (1/32)	2 (5/64)
	0.34 (22 AWG)	AI 0.34 - 6TQ	10.5 (13/32)	0.8 (1/32)	2 (5/64)
	0.5 (20 AWG)	AI 0.5 - 6WH	14 (9/16)	1.1 (3/64)	2.5 (3/32)

### ◆ Terminal Functions

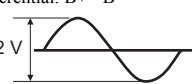

**Table 8 Option Terminal Functions (EnDat)**

Terminal Block	Terminal	Function	Description
TB1	IP	PG encoder power supply	Supplies power to the PG encoder. <ul style="list-style-type: none"> <li>• Jumper with terminal CN3 to select the power supply voltage, 5 V or 8 V.</li> <li>• Voltage range: 5 V <math>\pm</math>5%, 330 mA 8 V <math>\pm</math>10%, 150 mA</li> </ul> <b>Note:</b> The number of connections to terminals IP and IG differs by wiring length when the power supply is set for +5 V $\pm$ 5%. <ul style="list-style-type: none"> <li>• Up to 10 m: One or two connections to both IP and IG.</li> <li>• 10 to 20 m: Two connections to both IP and IG.</li> </ul>
	IG	PG encoder power supply common	
	DT	Communication data signal I/O	Reads and processes PG encoder data. Signal level: RS-485 protocol
	$\overline{\text{DT}}$	Inverse communication data signal I/O	
	B+	B phase signal input	Input for the B phase sine-wave from the PG encoder. <ul style="list-style-type: none"> <li>• Maximum input frequency: 20 kHz</li> <li>• Input signal differential: B+ - B-</li> </ul> <div style="text-align: center;">  <p style="margin: 0;">0.6 V to 1.2 V</p> </div> <b>Note:</b> Not available when using EnDat 2.2/22.
	B-	Inverse B phase signal input	
	b+	B phase monitor signal output	Outputs a ratio of the B phase frequency. <ul style="list-style-type: none"> <li>• Output method: Line driver</li> <li>• Output voltage: RS-422 level</li> <li>• Possible resolution: 1/n Set F1-06 to monitor the pulse signal. Varies by drive model.</li> </ul> <b>Note:</b> Not available when using EnDat 2.2/22.
	b-	Inverse B phase monitor signal output	

## 5 Installation Procedure

Terminal Block	Terminal	Function	Description
TB2	IP	PG encoder power supply	Supplies power to the PG encoder. Connects to terminal IP on the option.
	IG	PG encoder power supply common	Supplies power to the PG encoder. Connects to terminal IG on the option.
	CK	Communication clock signal output	Outputs the communication clock signal to the PG encoder. Signal level: RS-485 protocol
	$\overline{\text{CK}}$	Inverse communication clock signal output	
	A+	A phase signal input	Input for the A phase sine-wave from the PG encoder. <ul style="list-style-type: none"> <li>• Maximum input frequency: 20 kHz</li> <li>• Input signal differential: A+ - A-</li> </ul>  <b>Note:</b> Not available when using EnDat 2.2/22.
	A-	Inverse A phase signal input	
	a+	A phase monitor signal output	Outputs a ratio of the A phase frequency. <ul style="list-style-type: none"> <li>• Output method: Line driver</li> <li>• Output voltage: RS-422 level</li> <li>• Possible resolution ratio: 1/n</li> </ul> Set F1-06 to monitor the pulse signal. Varies by drive model. <b>Note:</b> Not available when using EnDat 2.2/22.
	a-	Inverse A phase monitor signal output	
	FE	Ground	Ground terminal for shielded cable.

**Table 9 Option Terminal Functions (HIPERFACE)**

Terminal Block	Terminal (Signal)	Function	Description
TB1	IP (Us)	PG encoder power supply	Supplies power to the PG encoder. <ul style="list-style-type: none"> <li>• Jumper with terminal CN3 to select the power supply voltage, 5 V or 8 V.</li> <li>• Voltage range: 5 V <math>\pm</math>5%, 330 mA 8 V <math>\pm</math>10%, 150 mA</li> </ul>
	IG (GND)	PG encoder power supply common	
	DT (Data+)	Communication data signal I/O	Reads and processes PG encoder data. Signal level: RS-485 protocol
	$\overline{DT}$ (Data-)	Inverse communication data signal I/O	
	B+ (+SIN)	SIN signal input	Input for the sine-wave from the PG encoder. <ul style="list-style-type: none"> <li>• Maximum input frequency: 20 kHz</li> <li>• Input signal differential: +SIN - REFSIN</li> </ul> 0.9 V to 1.1 V 
	B- (REFSIN)	Inverse SIN signal input	
	b+	SIN pulse monitor signal output	Outputs a ratio of the sine pulse frequency. <ul style="list-style-type: none"> <li>• Output method: Line driver</li> <li>• Output voltage: RS-422 level</li> <li>• Possible resolution: 1/n (n = 0 to 32) Set F1-06 to monitor the pulse signal.</li> </ul>
b-	Inverse SIN pulse monitor signal output		
TB2	IP (Us)	PG encoder power supply	Supplies power to the PG encoder. Connects to terminal IP on the option.
	IG (GND)	PG encoder power supply common	Supplies power to the PG encoder. Connects to terminal IG on the option.
	CK	-	Not used.
	$\overline{CK}$	-	
	A+ (+COS)	COS signal input	Input for the cosine-wave from the PG encoder. <ul style="list-style-type: none"> <li>• Maximum input frequency: 20 kHz</li> <li>• Input signal differential: +COS - REFCOS</li> </ul> 0.9 V to 1.1 V 
	A- (RSFCOS)	Inverse COS signal input	
	a+	COS pulse monitor signal output	Outputs pulses of the cosine signal frequency ratio. <ul style="list-style-type: none"> <li>• Output method: Line driver</li> <li>• Output voltage: RS-422 level</li> <li>• Possible resolution ratio: 1/n (n = 0 to 32) Set F1-06 to monitor the pulse signal.</li> </ul>
	a-	Inverse COS pulse monitor signal output	
FE	Ground	Ground terminal for shielded cable.	

# 6 Related Parameters

The following parameters set the drive for operation with the option. Set parameters as needed. Parameter setting methods can be found in the drive Quick Start Guide or Technical Manual.

**Table 10 Related Parameters**

No. (Addr. Hex)	Name	Description	Control Mode	Values
A1-02 (102)	Control Method Selection	0: V/f Control 1: V/f Control with PG 2: Open Loop Vector Control 3: Closed Loop Vector Control 5: Open Loop Vector Control for PM 6: Advanced Open Loop Vector Control for PM 7: Closed Loop Vector Control for PM <b>Note:</b> Set to 7 when using PG-F3.	All Modes	Default: </> Range: </>
F1-01 (380) </>	PG 1 Pulses per Revolution	Sets the signal periods per revolution to be read from the pulse generator.	CLV CLV/PM	Default: </> Min: </> Max: </>
F1-02 (381)	PG Feedback Loss Operation Selection	Sets the stopping method after PG disconnect (PGo). 0: Ramp to stop (decelerates at time set to C1-02) 1: Coast to stop 2: Fast Stop (decelerates at the time set to C1-09) 3: Continue running 4: No alarm display <b>NOTICE:</b> Due to potential damage to the motor and machinery, only use settings 3 and 4 under special circumstances.	CLV CLV/PM	Default: 1 Range: </>
F1-03 (382)	PG Overspeed Operation Selection	Sets the stopping method after detecting overspeed. 0: Ramp to stop (decelerates at time set to C1-02) 1: Coast to stop 2: Fast Stop (decelerates at the time set to C1-09) 3: Continue running <b>NOTICE:</b> Due to potential damage to the motor and machinery, do not use the "Continue running" setting except under special circumstances.	CLV CLV/PM	Default: 1 Range: 0 to 3
F1-04 (383)	PG Deviation Operation Selection	0: Ramp to stop (decelerates at time set to C1-02) 1: Coast to stop 2: Fast Stop (decelerates at the time set to C1-09) 3: Continue running <b>NOTICE:</b> Due to potential damage to the motor and machinery, do not use the "Continue running" setting except under special circumstances.	CLV CLV/PM	Default: </> Range: 0 to 3
F1-05 (384)	PG 1 Rotation	0: Forward = A pulse leads 1: Forward = B pulse leads	CLV CLV/PM	Default: </> Range: 0, 1



## 6 Related Parameters

No. (Addr. Hex)	Name	Description	Control Mode	Values
F1-06 (385)	PG 1 Ratio for PG Pulse Monitor	Sets the division ratio for PG encoder pulse output. Set as a three-digit number: x is the first digit, y is the second digit, and z is the third digit: When using the PG-F3 option, the drive disregards the value set for "x", and uses the formula $1/yz$ to determine the division rate for the pulse generator. The setting range is $1/32 : 1$ .	CLV CLV/PM	Default: 1 Min: 1 Max: 132
F1-08 (387)	PG Overspeed Level	Sets the level for detecting overspeed as a percentage of the maximum output frequency.	CLV CLV/PM	Default: 115 Min: 0 Max: 120
F1-09 (388)	Overspeed Det. Time	Sets the time required for the motor to exceed the level set in F1-08 to trigger a fault.	CLV CLV/PM	Default: 0.0 Min: 0.0 Max: 2.0
F1-10 (389)	Excessive Speed Deviation Det. Level	Sets the degree of speed deviation to trigger a dEv fault. Set as a percentage of the maximum output frequency.	CLV CLV/PM	Default: 10 Min: 0 Max: 50
F1-11 (38A)	Excessive Speed Deviation Det. Time	Sets the time required for a speed deviation situation to trigger a fault.	CLV CLV/PM	Default: 0.5 Min: 0.0 Max: 10.0
F1-14 (38D)	PG Disconnect Det. Time	Sets the time in seconds for PG encoder disconnect to be detected.	CLV CLV/PM	Default: 2.0 Min: 0.0 Max: 10.0
F1-18 (3AD)	Reverse Rotation Det. for PG 1	0: Disabled n: Number of times a dv3 situation must be detected to trigger a fault.	CLV/PM	Default: 10 Min: 0 Max: 10
F1-19 (3AE)	Reverse Rotation Det. for PG 1	0: Disabled n: Number of times a dv4 situation must be detected to trigger a fault.	CLV/PM	Default: 128 Min: 0 Max: 5000
F1-20 (3B4)	PG 1 Hardware Disconnect	0: Disabled. No fault if the connection is lost. 1: Enabled. Fault if connection is lost.	CLV CLV/PM	Default: 1 Range: 0, 1
F1-50 (3D2)	Encoder Selection	0: EnDat 2.1/2.2 Serial+Sin/Cos 1: EnDat 2.2 Serial only 2: HIPERFACE	CLV/PM	Default: 0 Range: 0 to 2
F1-51 (3D3)	PGoH Detection Level	Sets the level for detecting a PG Hardware Fault (PGoH). Set as a percentage of $\sqrt{\sin^2\theta + \cos^2\theta}$ .	CLV/PM	Default: 80 Min: 1 Max: 100

## 6 Related Parameters

No. (Addr. Hex)	Name	Description	Control Mode	Values
F1-52 (3D4)	Communication Speed Selection of Serial Encoder	Sets the communications speed between the serial encoder and the PG-F3 Option. This parameter can be set when F1-50 = 1. EnDat/HIPERFACE 0: 1 M/ 9600 bps 1: 500 k/19200 bps 2: 1 M/38400 bps (same as setting 0 when using EnDat 2.2/22) 3: 1 M/38400 bps (same as setting 0 when using EnDat 2.2/22)	CLV/PM	Default: 0 Range: 0 to 3

<1> Varies by drive model.

<2> The output frequency of the PG encoder can be calculated with the following formula:

$$\text{Operation at maximum output frequency (Hz)} = \frac{\text{Motor speed at maximum frequency output (r/min)}}{60} \times \text{PG rating (p/rev)}$$

## 7 Troubleshooting

### ◆ Drive-Side Error Codes

**Table 11** lists the various fault codes related to the option and pulse generator. Refer to the drive Technical Manual for further details on fault codes.



Check the following items first when an error code occurs on the drive:

- Are the cables connected properly and securely?
- Is the option properly installed to the drive?
- Did a momentary power loss occur?

**Table 11 Fault Displays, Causes, and Possible Solutions**



Digital Operator Display		Fault Name
$dEv$	dEv	Speed Deviation (for Control Mode with PG)
		The deviation between the speed reference and speed feedback is greater than the setting in F1-10 for longer than the time set to F1-11.
<b>Cause</b>		<b>Possible Solution</b>
The load is too heavy.		Reduce the load.
The acceleration and deceleration times are set too short or too long.		Increase or decrease the acceleration and deceleration times (C1-01 through C1-08).
The load is locked up.		Check the machine.
Parameters are set inappropriately.		Check the settings of parameters F1-10 and F1-11.
Motor brake is engaged.		Ensure the motor brake releases properly.
Brake control sequence is incorrect.		Correct the brake control sequence and verify that the brake is released.
Digital Operator Display		Fault Name
$dv3$	dv3	Inversion Detection
		<ul style="list-style-type: none"> <li>• Torque reference and acceleration are in opposite directions.</li> <li>• The speed reference and actual motor speed differ by over 30% for the number of pulses set to parameter F1-18.</li> </ul>
<b>Cause</b>		<b>Possible Solution</b>
E5-11 is not set properly.		Set the value for $\Delta\theta$ to E5-11 as specified on the motor nameplate.
An external force on the load side caused the motor to move.		<ul style="list-style-type: none"> <li>• Make sure the motor is rotating in the proper direction.</li> <li>• Investigate problems on the load side causing motor rotation in the opposite direction.</li> </ul>

## 7 Troubleshooting



Noise interference along the PG encoder cable is affecting the A channel or B channel.		<ul style="list-style-type: none"> <li>• Check PG encoder wiring and make sure all wiring including shielded wiring is properly connected.</li> <li>• If the problem continues after cycling power, replace the PG option or the PG encoder.</li> </ul>
The PG encoder is disconnected or is not wired properly, or the PG option or PG encoder are damaged.		
The PG encoder rotational direction set to F1-05 is in the opposite direction of the motor wiring.		Make sure motor wiring for each phase (U, V, W) is connected properly.
Digital Operator Display		Fault Name
	dv4	Inversion Prevention Detection
		Pulses indicate that the motor is rotating in the opposite direction of the speed reference. Set the number of pulses to trigger inverse detection to F1-19. <b>Note:</b> To avoid nuisance faults, be sure to disable inverse detection in applications where the motor may rotate in the opposite direction of the speed reference. Set F1-19 to 0 to disable this feature.
Cause		Possible Solution
E5-11 is not set properly.		<ul style="list-style-type: none"> <li>• Set the value for <math>\Delta\theta</math> to E5-11 as specified on the motor nameplate.</li> <li>• If the problem continues after cycling power, replace the PG option or the PG encoder.</li> </ul>
Noise interference along the PG encoder cable is affecting the A or B phase.		<ul style="list-style-type: none"> <li>• Make sure the motor is rotating in the proper direction.</li> <li>• Investigate problems on the load-side that may be causing the motor to rotate in the opposite direction.</li> </ul>
PG encoder is disconnected or is not wired properly, or the PG option or PG encoder are damaged.		<ul style="list-style-type: none"> <li>• Check PG encoder wiring and make sure all wiring including shielded wiring is properly connected.</li> <li>• If the problem continues after cycling power, replace the PG option or the PG encoder.</li> </ul>
Digital Operator Display		Fault Name
	oFA00	Non-compatible option is connected to drive port CN5-A.
Cause		Possible Solution
Non-compatible option is connected to drive port CN5-A.		Use only compatible options. Connect PG-F3 to CN5-C. For other options, refer to the Installation Manual for that option.
Digital Operator Display		Fault Name
	oFb00	Non-compatible option is connected to drive port CN5-B.
Cause		Possible Solution
Non-compatible option is connected to drive port CN5-B.		Use only compatible options. Connect PG-F3 to CN5-C. For other options, refer to the Installation Manual for that option.

Digital Operator Display		Fault Name
oFC01	oFC01	Option Connection Error at drive port CN5-C
<b>Cause</b>		<b>Possible Solution</b>
Option at drive port CN5-C was changed during run.		Switch the power off and reconnect the option.
Digital Operator Display		Fault Name
oFC50	oFC50	PG Encoder Option A/D Conversion Error
		Error with the A/D conversion level (VCC level), or A/D conversion timed out.
<b>Cause</b>		<b>Possible Solution</b>
The option is damaged.		Replace the option.
Digital Operator Display		Fault Name
oFC51	oFC51	PG Encoder Option Analog Circuit Error
		Incorrect signal level (+2.5 V signal)
<b>Cause</b>		<b>Possible Solution</b>
The option is damaged.		Replace the option.
Digital Operator Display		Fault Name
oFC52	oFC52	PG Encoder Communication Timeout
		Serial encoder timed out waiting to receive data
<b>Cause</b>		<b>Possible Solution</b>
PG encoder wiring is incorrect.		Correct the wiring.
PG encoder cable is disconnected.		Reconnect the cable.
F1-50 (Encoder selection) is incorrect.		Set F1-50 (Encoder selection) according to the encoder connected to the drive.
Digital Operator Display		Fault Name
oFC53	oFC53	PG Encoder Communication Data Error
		Serial encoder CRC checksum error
<b>Cause</b>		<b>Possible Solution</b>
PG encoder wiring is incorrect.		Correct the wiring.
PG encoder cable is disconnected.		Reconnect the cable.
Digital Operator Display		Fault Name
oFC54	oFC54	PG Encoder Error
		Alarm reading EnDat absolute position data from the PG encoder (OR flag from EnDat error for overvoltage, undervoltage, etc.)
<b>Cause</b>		<b>Possible Solution</b>
Power supply to PG encoder is wired incorrectly.		Correct the wiring.

## 7 Troubleshooting

PG-F3 power supply circuit is damaged.		Replace the option.
Digital Operator Display		Fault Name
	oS	Overspeed
		The motor speed feedback exceeded the F1-08 setting.
Cause		Possible Solution
Overshoot is occurring.		Increase the settings for C5-01 (Speed Control Proportional Gain 1) and reduce C5-02 (Speed Control Integral Time 1).
Incorrect speed feedback scaling when terminal RP is used as speed feedback input in V/f control.		<ul style="list-style-type: none"> <li>Set H6-02 to the value of the speed feedback signal frequency when the motor runs at the maximum speed.</li> <li>Adjust the input signal using parameters H6-03 through H6-05.</li> </ul>
Incorrect PG encoder pulse number set.		Check and correct parameter F1-01.
Inappropriate parameter settings.		Check the setting for the overspeed detection level and the overspeed detection time (F1-08 and F1-09).
Digital Operator Display		Fault Name
	PGo	PG Encoder Disconnected
		Detected when no PG encoder pulses have been received for a time longer than is set to F1-14.
Cause		Possible Solution
PG encoder cable is disconnected.		Reconnect the cable.
PG encoder wiring is incorrect.		Correct the wiring.
PG encoder does not have enough power.		Make sure the correct power supply is properly connected to the PG encoder.
Brake control sequence is incorrect.		Correct the brake control sequence and verify that the brake has been released.
Digital Operator Display		Fault Name
	PGoH	PG Encoder Hardware Fault
		PG encoder cable is disconnected.
Cause		Possible Solution
PG encoder cable is disconnected.		Reconnect the cable.

**Table 12 Operation Error Displays, Causes, and Possible Solutions**

Digital Operator Display		Fault Name
	oPE02	Parameter Range Setting Error Use U1-18 to find parameters set outside range.
Cause		Possible Solution
Parameters were set outside the possible range.		Set parameters to the proper values. <b>Note:</b> When multiple errors occur simultaneously, other errors are given precedence over oPE02.
Digital Operator Display		Fault Name
	oPE06	Control Method Selection Error Correct the setting for the control method.
Cause		Possible Solution
Control mode requires installing a PG option, but no PG option is installed (A1-02 = 7).		Connect a PG option.

## 7 Troubleshooting

### ◆ Preventing Noise Interference

Take the following steps to prevent erroneous operation caused by noise interference:

- Use shielded wire for the PG encoder signal lines.
- Limit the length of all motor output power cables to less than 20 m.
- The signal “Sensor Up” must be connected to terminal IP on the PG-F3 option for cables longer than 10 m. Additionally, the “Sensor 0 V” must be connected to terminal IG.
- Use separate conduit or cable tray dividers to separate option control wiring, main circuit input power wiring, and motor output power cables.
- Ground the shield on the PG encoder side and the drive side. If electrical interference problems arise in the PG encoder signal, verify that the shield is properly grounded and ground one end of the signal line or remove the ground connection on both ends.
- Properly connect the shield in cable to the IG on the option terminal or remove the ground connection on both ends.

### ■ Interface Circuit

EnDat 2.1/01, EnDat 2.2/01

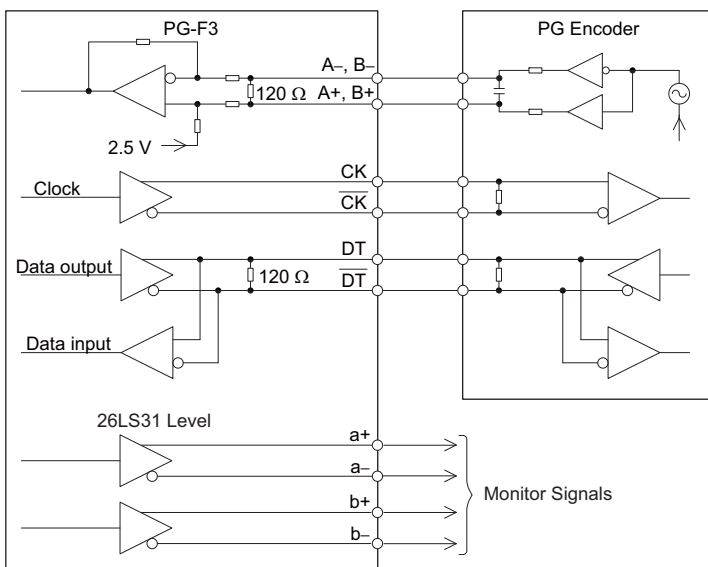
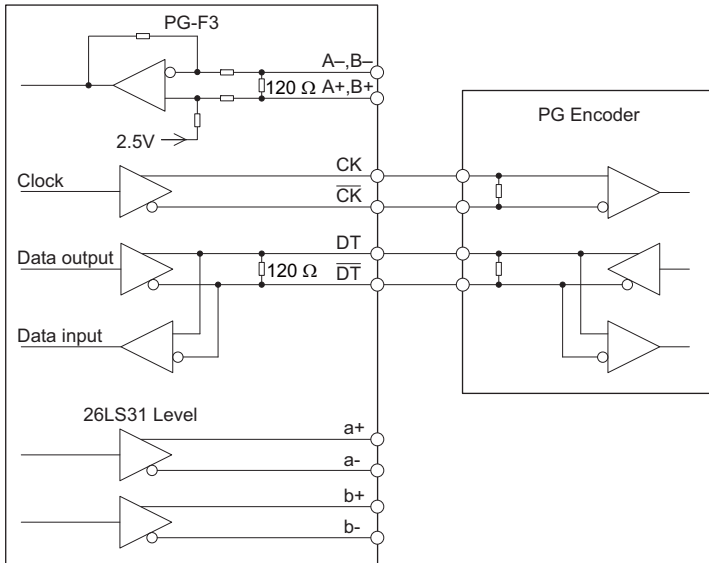

Figure 14 Interface Circuit (EnDat 2.1/01, EnDat 2.2/01)



## EnDat 2.2/22



**Figure 15 Interface Circuit (EnDat 2.2/22)**

# 7 Troubleshooting

## HIPERFACE

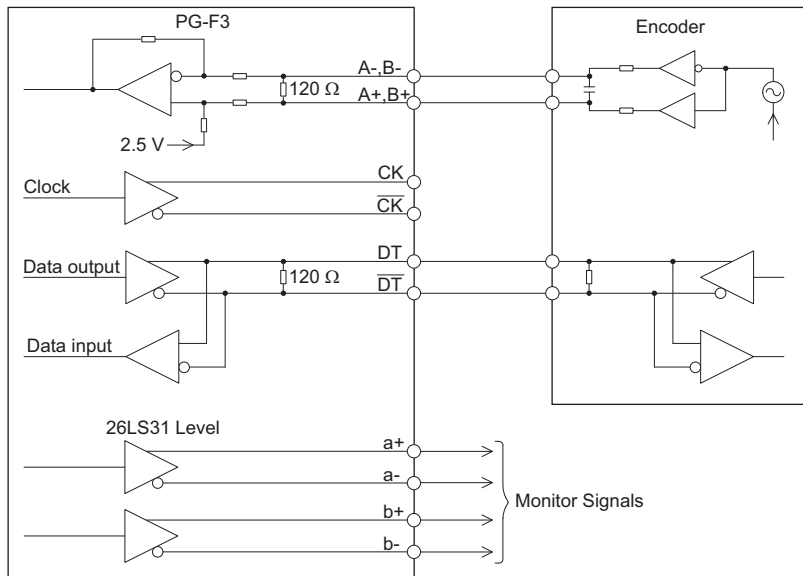

Figure 16 Interface Circuit (HIPERFACE)

# 8 Specifications

Table 13 Option Specifications

Items	Specifications
<b>Model</b>	PG-F3
<b>Compatible PG Encoder Types</b>	EnDat 2.1/01, EnDat 2.2/01, EnDat 2.2/22 (HEIDENHAIN) ECN1313 (EnDat 2.1/01, EnDat 2.2/01) ECN113 (EnDat 2.1/01, EnDat 2.2/01) ECN413 (EnDat 2.1/01, EnDat 2.2/01) ECN1325 (EnDat 2.2/22) ECN125 (EnDat 2.2/22) ECN425 (EnDat 2.2/22) HIPERFACE (SICK STEGMANN) SRS50/60 SKS36 SFS60
<b>Multi-turn</b>	Not available
<b>PG Encoder Wiring Length</b>	20 m (65 ft. ) maximum. Wiring length over 10 m (32 ft.) for EnDat requires two connections to both IP and IG.
<b>PG Encoder Power Supply</b>	Output voltage: 5 V $\pm$ 5%, 8 V $\pm$ 10% Maximum Output Current: 330 mA (5 V), 150 mA (8 V)
<b>Compatible Control Modes</b>	Closed Loop Vector for PM motors
<b>Maximum Input Frequency</b>	20 kHz (no maximum input frequency for EnDat 2.2/22)
<b>Pulse Monitor Output</b>	Monitor for A and B phase output Matches RS-422 Level <b>Note:</b> Not available when using EnDat 2.2/22.
<b>PG Encoder Disconnect Detection</b>	Software detection
<b>Ambient Temperature</b>	-10°C to 50°C (14°F to 122°F)
<b>Humidity</b>	95% RH or lower with no condensation
<b>Storage Temperature</b>	-20°C to 60°C (-4°F to 140°F) allowed for short-term transport of the product
<b>Area of Use</b>	Indoor (free of corrosive gas, airborne particles, etc.)
<b>Altitude</b>	1000 m (3280 ft.) or lower







## ◆ Revision History

Revision dates and manual numbers appear on the bottom of the back cover.

MANUAL NO. TOBP C730600 51B

Published in Japan November 2009 09-7 

└─ Revision number  
└─ Date of original publication  
└─ Date of publication

Date of Publication	Rev. No	Section	Revised Content
March 2013		Entire Document	Addition: HIPERFACE added along with corresponding data.
		Back cover	Revision: Address
October 2012		Chapter 2	Revision: Revised in accordance with software and hardware upgrade.
		Back cover	Revision: Address
July 2012		Back cover	Revision: Address
July 2011		Entire Document	Addition: EnDat 2.2/22 added along with corresponding data.
January 2011		Front cover	Revision: Format
		Back cover	Revision: Address, format
March 2010		Entire Document	Edited for procedural clarity and readability.
November 2009		Entire Document	Edited for procedural clarity and readability.
July 2009	–	–	First edition

# YASKAWA AC Drive 1000-Series Option Motor Encoder Feedback (EnDat, HIPERFACE) Interface Installation Manual

---

## DRIVE CENTER (INVERTER PLANT)

2-13-1, Nishimiyachi, Yukufashi, Fukuoka, 824-8511, Japan  
Phone: 81-930-25-3844 Fax: 81-930-25-4369  
<http://www.yaskawa.co.jp>

## YASKAWA ELECTRIC CORPORATION

New Pier Takeshiba South Tower, 1-16-1, Kaigan, Minatoku, Tokyo, 105-6891, Japan  
Phone: 81-3-5402-4502 Fax: 81-3-5402-4580  
<http://www.yaskawa.co.jp>

## YASKAWA AMERICA, INC.

2121 Norman Drive South, Waukegan, IL 60085, U.S.A.  
Phone: (800) YASKAWA (827-6292) or 1-847-887-7000 Fax: 1-847-887-7310  
<http://www.yaskawa.com>

## YASKAWA ELÉTRICO DO BRASIL LTDA.

Avenida Fagundes Filho, 620 Bairro Saudes, São Paulo, SP04304-000, Brazil  
Phone: 55-11-3585-1100 Fax: 55-11-5581-8795  
<http://www.yaskawa.com.br>

## YASKAWA EUROPE GmbH

Hauptstrasse 185, 65760 Eschborn, Germany  
Phone: 49-6196-569-300 Fax: 49-6196-569-398  
<http://www.yaskawa.eu.com>

## YASKAWA ELECTRIC UK LTD.

1 Hunt Hill Orchardton Woods, Cumbernauld, G68 9LF, United Kingdom  
Phone: 44-1236-735000 Fax: 44-1236-458182  
<http://www.yaskawa.co.uk>

## YASKAWA ELECTRIC KOREA CORPORATION

9F Kyobo Securities Bldg., 26-4, Yeouido-dong, Yeongdeungpo-gu, Seoul, 150-737, Korea  
Phone: 82-2-784-7844 Fax: 82-2-784-8495  
<http://www.yaskawa.co.kr>

## YASKAWA ELECTRIC (SINGAPORE) PTE. LTD.

151 Lorong Chuan, #04-01, New Tech Park, 556741, Singapore  
Phone: 65-6282-3003 Fax: 65-6289-3003  
<http://www.yaskawa.com.sg>

## YASKAWA ELECTRIC (CHINA) CO., LTD.

12F, Carlton Bld., No.21 HuangHe Road, HuangPu District, Shanghai 200003, China  
Phone: 86-21-5385-2200 Fax: 86-21-5385-3299  
<http://www.yaskawa.com.cn>

## YASKAWA ELECTRIC (CHINA) CO., LTD. BEIJING OFFICE

Room 1011, Tower W3 Oriental Plaza, No. 1 East Chang An Ave.,  
Dong Cheng District, Beijing, 100738, China  
Phone: 86-10-8518-4086 Fax: 86-10-8518-4082

## YASKAWA ELECTRIC TAIWAN CORPORATION

9F, 16, Nanking E. Rd., Sec. 3, Taipei, 104, Taiwan  
Phone: 886-2-2502-5003 Fax: 886-2-2505-1280

## YASKAWA ELECTRIC INDIA PRIVATE LIMITED

#17/A Electronics City, Hosur Road Bangalore 560 100 (Karnataka), India  
Phone: 91-80-4244-1900 Fax: 91-80-4244-1901  
<http://www.yaskawaindia.in>

---



YASKAWA ELECTRIC CORPORATION

In the event that the end user of this product is to be the military and said product is to be employed in any weapons systems or the manufacture thereof, the export will fall under the relevant regulations as stipulated in the Foreign Exchange and Foreign Trade Regulations. Therefore, be sure to follow all procedures and submit all relevant documentation according to any and all rules, regulations and laws that may apply.

Specifications are subject to change without notice for ongoing product modifications and improvements.

© 2009-2013 YASKAWA ELECTRIC CORPORATION. All rights reserved.

MANUAL NO. TOBP C730600 51F

Published in Japan March 2013 09-7  0  
12-7-9