

YASKAWA

EtherCAT Option

Options Card for AC Drives and Regenerative Units Installation Manual

Type: SI-ES3
SI-ES3/V

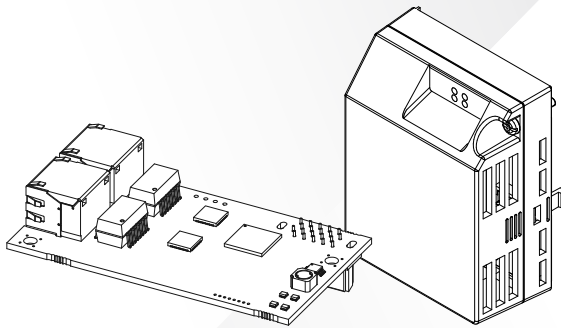



This Page Intentionally Blank

Table of Contents

1.	Preface and General Precautions	5
	Safety Information	5
	General Safety Instructions	5
	Intended Use	7
	Legal Information	8
2.	Product Overview	8
	About This Product	8
	Applicable Models	9
3.	Receiving	9
4.	EtherCAT Option Components	11
	EtherCAT Option SI-ES3	11
	EtherCAT Option SI-ES3/V for V1000	12
	EtherCAT Option Status LEDs	12
	Indicator Flash Rates	14
	Connecting the Option Card	14
5.	Mechanical & Electrical Installation	15
	Safety Precautions	15
	Preconditions for Installing the Option Card	16
	Installing the Option on a A1000, D1000, R1000, or U1000	16
	Installing the Option on a V1000	18
	Installing the Option on a GA800, or GA700	20
	Installing the Option on a GA500	23
	Installing the Option on a Q2A	24
	Installing the Option on a Q2V	27
	ESI File	27
6.	EtherCAT Option Related Drive Parameters	28
	Parameters for A1000, D1000, R1000, U1000, GA800, GA700, GA500, CR700, V1000	28
	Parameters for Q2A, Q2V	29
7.	Troubleshooting	31
	Communication Option Card Error Codes	31

Emergency Error Codes	31
Yaskawa-specific SDO Abort Codes	39
Fault	39
Option Board Error Management	41
Minor Faults/Alarms	42
8. Disposal	43
Disposal Instructions	43
WEEE Directive	43
9. Specifications	44
Revision History	45

1 Preface and General Precautions

This chapter describes important safety precautions regarding the use of this product. Failure to follow these precautions may result in serious injury or death, and may lead to damage to this product or related devices and systems. Yaskawa shall not be held responsible for any injury or equipment damage as a result of failure to observe the precautions and instructions contained in this manual.

◆ Safety Information

Read and understand this manual before you install, operate, or do maintenance on the drive. Install the drive as specified by this manual and local codes.

The symbol marks in this section identify safety messages in this manual. Failure to obey these safety messages can cause serious injury, death, or damage to the products and related equipment and systems.

These identifier words categorize and emphasize important safety precautions in these instructions.

DANGER

Identifies a hazardous situation, which, if not avoided, will cause death or serious injury.

WARNING

Identifies a hazardous situation, which, if not avoided, can cause death or serious injury.

CAUTION

Identifies a hazardous situation, which, if not avoided, can cause minor or moderate injury.

NOTICE

Identifies a property damage message.

■ General Safety Instructions

Yaskawa Electric manufactures and supplies electronic components for a variety of industrial applications. The selection and application of Yaskawa products is the responsibility of the designer of the equipment or the customer that assembles the final product. Yaskawa is not responsible for how our products are incorporated into the final system design. In all cases, Yaskawa products should not be incorporated into a product or design as the exclusive or sole safety control function. All control functions are designed to dynamically detect failures and operate safely without exception. All products that are designed to incorporate parts manufactured by Yaskawa must be provided to the end user and include proper warnings and instructions regarding their safe use and operation. All warnings from Yaskawa must be promptly issued to the end user. Yaskawa offers warranties only for the quality of our products, in compliance with standards and specifications that are described in the manual. Yaskawa does not offer other warranties, either explicit or implied. Injuries, property damage, and lost business opportunities caused by improper storage or handling and negligence oversight on the part of your company or your customers will void Yaskawa's warranty for the product.

Note:

Failure to obey the safety messages in the manual can cause serious injury or death. Yaskawa is not responsible for injuries or damage to equipment caused by ignoring the safety messages.

- Read this manual carefully when mounting, operating, and repairing AC drives.
- Obey all warnings, cautions, and notices.
- Approved personnel must perform all work.
- Install the drive in an area with these conditions.

DANGER

Electrical Shock Hazard. Do not examine, connect, or disconnect wiring on an energized drive. Before servicing, disconnect all power to the equipment and wait for the time specified on the warning label at a minimum. The internal capacitor stays charged after the drive is de-energized. The charge indicator LED extinguishes when the DC bus voltage decreases below 50 Vdc. When all indicators are OFF, remove the covers before measuring for dangerous voltages to make sure that the drive is safe. Failure to obey will cause death or serious injury.

▲ WARNING *Fire Hazard. Do not connect power supply wiring to drive output terminals U/T1, V/T2, and W/T3. Connect power supply wiring to main circuit input terminals R/L1, S/L2, and T/L3. Failure to obey can cause death or serious injury.*

▲ WARNING *Crush Hazard. Only approved personnel can operate a crane or hoist to move the drive. Failure to obey can cause death or serious injury from falling equipment.*

▲ WARNING *Electrical Shock Hazard. Do not make changes to the drive body or drive circuitry. Failure to obey can cause death or serious injury and will void warranty. Yaskawa is not responsible for changes to the product made by the user.*

▲ WARNING *Electrical Shock Hazard. Only let authorized persons install, wire, maintain, examine, replace parts, and repair the drive. Failure to obey can cause death or serious injury.*

▲ WARNING *Electrical Shock Hazard. Always ground the motor-side grounding terminal. Contacting the motor case can cause death or serious injury from incorrect equipment grounding.*

▲ WARNING *Electrical Shock Hazard. Do not work on the drive or around the drive while wearing loose clothing or jewelry. Tighten loose clothing and remove all metal objects such as watches or rings. Failure to obey can cause death or serious injury.*

▲ WARNING *Electrical Shock Hazard. The leakage current of the drive will be more than 3.5 mA in some drive models. The IEC/EN 61800-5-1: 2007 standard specifies that users must wire the power supply to automatically turn off when the protective ground wire disconnects. Users can also connect a protective ground wire that has a minimum cross-sectional area of 10 mm² (copper wire) or 16 mm² (aluminum wire). Failure to obey these standards can cause death or serious injury.*

▲ WARNING *Sudden Movement Hazard. Remove all persons and objects from the area around the drive, motor, and load before starting Auto-Tuning. The drive and motor can start suddenly during Auto-Tuning and cause death or serious injury.*

▲ WARNING *Sudden Movement Hazard. Remove all persons and objects from the area around the drive, motor, and machine area and attach covers, couplings, shaft keys, and machine loads before energizing the drive. Failure to obey can cause death or serious injury.*

▲ WARNING *Fire Hazard. Do not use the main circuit power supply (Overcurrent Category III) at incorrect voltages. Make sure that the drive rated voltage aligns with the power supply voltage before energizing the drive. Failure to obey can cause death or serious injury.*

▲ WARNING *Fire Hazard. Do not put flammable or combustible materials on top of the drive and do not install the drive near flammable or combustible materials. Attach the drive to metal or other noncombustible material. Failure to obey can cause death or serious injury.*

▲ WARNING *Fire Hazard. Tighten all terminal screws to the correct tightening torque. Connections that are too loose or too tight can cause incorrect operation and damage to the drive. Incorrect connections can also cause death or serious injury from fire.*

▲ WARNING *Fire Hazard. Tighten screws against the bit at an angle in the specified range described in this manual. Tightening screws at an angle outside of the specified range can cause damage the terminal block or start a fire if the connection is loose.*

▲ WARNING *Crush Hazard. Use a lifting mechanism made to move large drives when necessary. Failure to obey can cause death or serious injury from falling equipment.*

▲ WARNING *Electrical Shock Hazard. Do not cause a short circuit on the drive output circuit. Failure to obey can cause death or serious injury.*

▲ WARNING *Electrical Shock Hazard. Always use a type B Residual Current Monitor/Residual Current Device (RCM/RCD) where a residual current operated protective or monitoring device protects against direct or indirect contact as specified by IEC/EN 60755. The drive can cause a residual current with a DC component in the protective earthing conductor. Failure to obey can cause death or serious injury.*

▲ WARNING *Electrical Shock Hazard. Ground the neutral point on the power supply of drive models 2xxxB/C and 4xxxA/B/C to comply with the EMC Directive before turning on the EMC filter or if there is high resistance grounding. If the EMC filter is switched ON without the neutral point being grounded or if there is high resistance grounding, it can cause death or serious injury.*

Test

⚠ WARNING *Electrical Shock Hazard. Do not immediately energize the drive or operate peripheral devices after the drive blows a fuse or trips an RCM/RCD. Wait for the time specified on the warning label at a minimum and make sure that all indicators are OFF. Then check the wiring and peripheral device ratings to find the cause of the problem. Contact Yaskawa before energizing the drive or peripheral devices if the cause is not known. Failure to obey can cause death or serious injury and damage to the drive.*

⚠ WARNING *Fire Hazard. Install sufficient branch circuit short circuit protection as specified by applicable codes and this manual. The drive is suited for circuits that supply not more than 100,000 RMS symmetrical amperes, 240 Vac maximum (200 V Class), 480 Vac maximum (400 V Class). Failure to obey can cause death or serious injury.*

⚠ CAUTION *Crush Hazard. Do not hold the drive by the front cover or terminal cover. Tighten the screws correctly before moving the drive. Failure to obey can cause minor to moderate injury.*

⚠ CAUTION *Burn Hazard. Do not touch a hot drive heatsink. De-energize the drive, wait 15 minutes minimum, and make sure that the heatsink is cool to replace the cooling fans. Failure to obey can cause minor to moderate injury.*

NOTICE *Observe correct electrostatic discharge (ESD) procedures when touching the drive and circuit boards. Failure to obey can cause ESD damage to the drive circuitry.*

NOTICE *Do not connect or disconnect the motor from the drive while the drive is supplying voltage. Incorrect equipment sequencing can cause damage to the drive.*

NOTICE *Do not do a withstand voltage test or Megger test on the drive. Failure to obey can cause damage to the drive.*

NOTICE *Do not connect or operate damaged equipment or equipment with missing parts. Failure to obey can cause damage to the drive and connected equipment.*

NOTICE *Install fuses and an RCM/RCD. Failure to obey can cause damage to the drive.*

NOTICE *Do not use unshielded wire for control wiring. Use shielded, twisted-pair wires and ground the shield to the ground terminal of the drive. Failure to obey can cause electrical interference and unsatisfactory system performance.*

NOTICE *Do not allow unqualified personnel to use the product. Before you connect a dynamic braking option to the drive, make sure that you review Braking Unit and Braking Resistor Unit Installation Manual TOBPC72060001. Failure to obey can cause damage to the drive and braking circuit.*

NOTICE *Make sure that all connections are correct after you install the drive and connecting peripheral devices. Failure to obey can cause damage to the drive.*

NOTICE *Do not connect phase-advancing capacitors or LC/RC noise filters to the output circuits. Failure to obey can cause damage to the drive, phase-advancing capacitors, LC/RC noise filters, and leakage breakers (ELCB, GFCI, or RCM/RCD).*

■ Intended Use

This communication option card is electrical equipment intended to enable Yaskawa drives to communicate with an additional fieldbus system for commercial use. Do not use this product for any other purpose.

1. Read and understand all safety precautions.
2. Wire and ground the drive and communication option card in accordance with all applicable standards and safety precautions.
3. Firmly attach all parts and protective covers.
4. Always use the product in the proper environmental conditions as specified in this manual.

⚠ DANGER *Electrical Shock Hazard. Make sure that all electrical connections are correct and install all drive covers before energizing the drive. Use terminals for their intended function only. Incorrect wiring or ground connections, and incorrect repair of protective covers can cause death or serious injury.*

⚠ WARNING *Electrical Shock Hazard. Do not make changes to the drive body or drive circuitry. Failure to obey can cause death or serious injury and will void warranty. Yaskawa is not responsible for changes to the product made by the user.*

◆ Legal Information

■ Exclusion of Liability

This product is not designed and manufactured for use in life-support machines or systems.

Contact a Yaskawa representative or your Yaskawa sales representative if you are considering the application of this product for special purposes, such as machines or systems used for passenger cars, medicine, airplanes and aerospace, nuclear power, electric power, or undersea relaying.

⚠ WARNING *Injury to Personnel. Yaskawa manufactured this product with strict quality-control guidelines. Install applicable safety devices to minimize the risk of accidents when installing the product where its failure could cause a life-or-death situation, loss of human life, or a serious accident or physical injury.*

■ About Registered Trademarks

- EtherCAT® is a registered trademark of Beckhoff Automation GmbH.
- Other company names and product names that appear in this document are trademarks or registered trademarks of the respective companies.

2 Product Overview

◆ About This Product

The EtherCAT Communication Option (Models: SI-ES3 and SI-ES3/V) is an option card designed to connect the YASKAWA AC drives or regenerative units to an EtherCAT network. Using this option card and an EtherCAT master you can:

- Operate the AC drive or regenerative unit
- Monitor the AC drive or regenerative unit operation status
- Read or modify AC drive or regenerative unit parameters.

The option contains support for the Velocity mode according the CANopen Device Profile and Motion Control (DSP402) profile. It also contains YASKAWA vendor specific CANopen objects based on the present CANopen option board specification.

The EtherCAT Option supports the following communication profiles:

- DS 301 Ver. 4.02
- DSP 402 Ver. 3.0 Velocity Mode (not available for D1000 and R1000)



EtherCAT®

◆ Applicable Models

The option can be used with these drive series:

Table 2.1 Applicable Models

Drive Series	Software Version	Drive Series	Software Version
Option Card Model: SI-ES3			
A1000	For models up to 630 kW: VSA901017 and higher For models more than 630 kW: VSA903015 and higher	GA800	VSAA09010 and higher
D1000	For models up to 630 kW: VSD902006 and higher For models more than 630 kW: VSD903014 and higher	GA700	VSAA1010 and higher
R1000	VSD902102 and higher	GA500	VSPA01010 and higher
U1000	VSU901010 and higher	Q2A	VSAA923010 and higher
		Q2V	VSPA22010 and higher
		CR700	VSRA01013 and higher
		Option Card Model: SI-ES3/V	
		V1000	VSV901020 and higher

For software version, see “PRG” on the nameplate of the drive or regenerative unit.

3 Receiving

Please perform the following tasks after receiving the Communication Option card:

- Inspect the Communication Option card for damage. If the Communication Option card appears damaged upon receipt, contact the shipping company immediately.
- Verify receipt of the correct model by checking the information:
For V1000: Find the information on the mounting frame label of the option card.
For other units: Find the information on the PCB.
- If you have received the wrong option card model or the Communication Option card does not function properly, contact your supplier.

◆ Packaging Content

Table 3.1 Option Package Contents for SI-ES3 (AC Drives and Regenerative Units)



Description	Option Card	Ground Cables	Screws (M3)	LED Label	Installation Manual
Illustration					
Quantity	1	1	3	2	1

Table 3.2 Option Package Contents for SI-ES3/V (V1000 AC Drive)



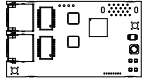

Description	Option Card	Ground Cables	Installation Manual
Illustration			
Quantity	1	4; of different length	1

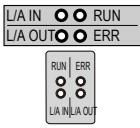
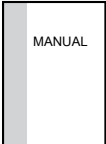
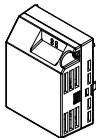
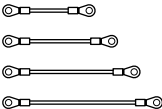
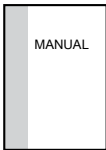
◆ Labels to be Attached to the Product

Attach the following labels to the end product to make sure the product remains CE compliant.

Note:

If the end product shall comply with UL directives, do not attach the stickers to the product.

Label	Description
	Read the manual. Obey the safety messages in the manual to prevent any kind of damage to humans, or to the equipment.
	Electrical Shock Hazard. Correctly ground the drive before you turn on the EMC filter switch. If you touch electrical equipment that is not grounded, it can cause serious injury or death.
	Electrical Shock Hazard. De-energize the drive and wait 5 minutes minimum until the Charge LED turns off. Remove the front cover and terminal cover to do work on wiring, circuit boards, and other parts. Use terminals for their correct function only. Incorrect wiring, incorrect ground connections, and incorrect repair of protective covers can cause death or serious injury.
 5 min	

4 EtherCAT Option Components

◆ EtherCAT Option SI-ES3

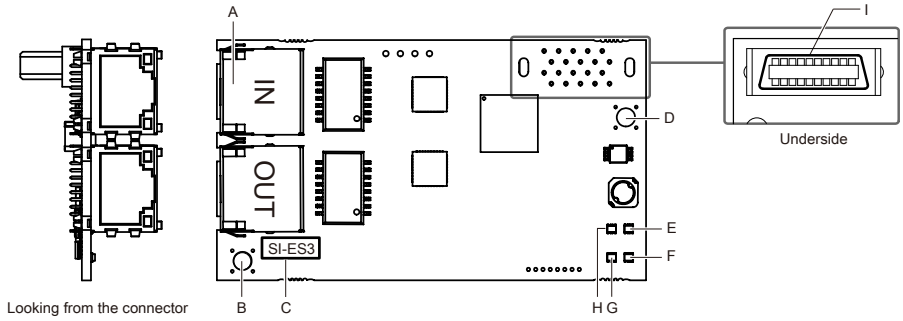

- | | |
|--|---------------------|
| A - Communication cable connector (RJ45) | F - LED (ERR) |
| B - Ground terminal (installation hole) | G - LED (L/A OUT) |
| C - Model number | H - LED (L/A IN) |
| D - Installation hole | I - Connector (CN5) |
| E - LED (RUN) | |

Figure 4.1 Option Card

◆ EtherCAT Option SI-ES3/V for V1000

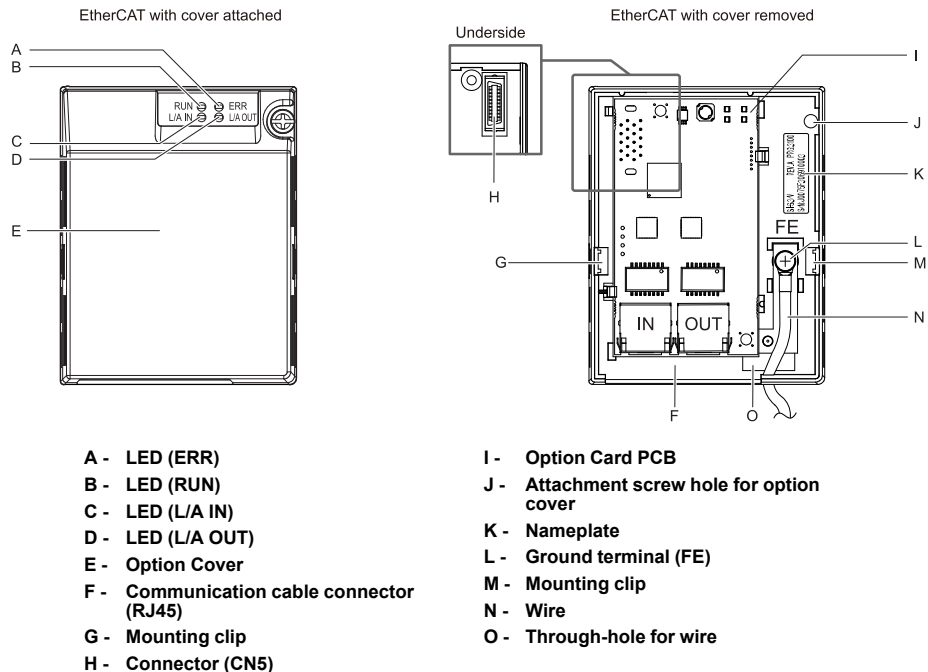

Figure 4.2 Option Card for V1000

◆ EtherCAT Option Status LEDs

The EtherCAT Option has four LEDs that indicate the communication status. The indications conform with DS303, Part 3: Indicator Specification.

■ LEDs L/A OUT and L/A IN: Ethernet Link/Activity Output and Input

The Link/Activity indicators show the status of the physical link and show activity on the link period.

LED	Color	Display	Meaning
Link Activity OUT	–	Off	No link. The communication cable is not physically connected. The communication controller is not started up.
Link Activity IN	Green	On	The module is connected to Ethernet. A communication cable is physically connected, but no data is being exchanged.
	Green	Flickering	There is traffic on Ethernet, data is being exchanged.

■ RUN LED

A green lit RUN LED indicates the status of the communication network state machine.

A red lit RUN LED is only used by the NOID firmware loader.

LED	Color	Display	Meaning
RUN	–	Off	The device is in Init state.
	Green	Blinking	The device is in Pre-Operational State.
	Green	Single flash	The device is in Safe-Operational State.
	Green	On	The device is in Operational State.
	Red	Blinking (1 Hz or 6 Hz)	The Option BOOT or APP firmware is executing the NOID firmware loader. 1 Hz: Firmware loader protocol in IDLE state (waiting for commands from the drive) 6 Hz: Firmware loader protocol is processing commands

■ ERR LED

The red error LED indicates the presence of any errors.

LED	Color	Display	Meaning
ERR	–	Off	No link. The communication option card is in working condition.
	Red	Blinking	General configuration error.
		Single flash	The slave device application has changed the communication state autonomously: The parameter "Change" in the AL status register is set to 01 (Hex): change/error.
		Double flash	The sync manager watchdog time out has occurred.
		On	Possible causes: 1: A Process Data Interface error has occurred, the NOID application interface has failed. 2: An option card FATAL event has occurred (system has stalled execution, see object 4000 (Hex) for the cause).
Blinking (1 Hz or 6 Hz)	The option BOOT or APP firmware is executing the NOID firmware loader. 1 Hz: Firmware loader protocol in IDLE state (waiting for commands from drive) 6 Hz: Firmware loader protocol is processing commands		

■ Indicator Flash Rates

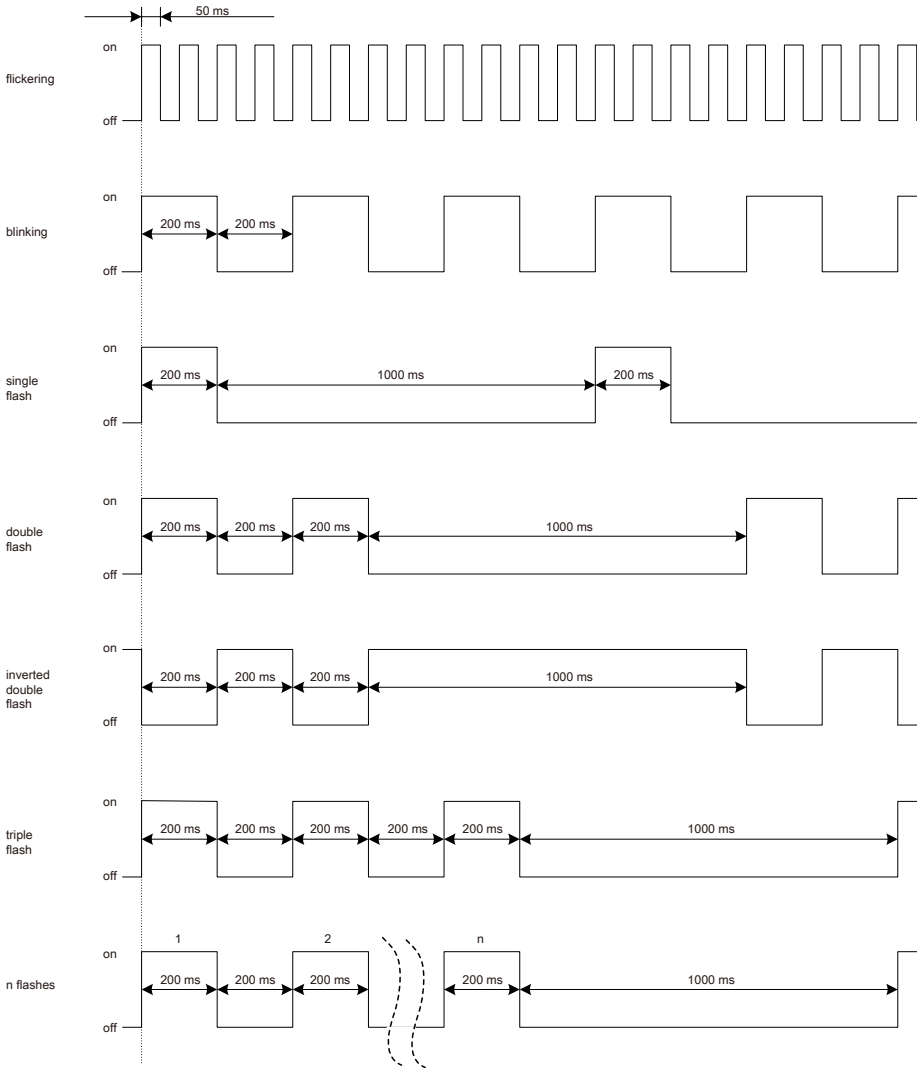

Figure 4.3 Meaning of LED Flash Rates

◆ Connecting the Option Card

■ Communication Connector

The Communication Option card is connected to the network using a RJ45 connector.

Table 4.1 Pin Assignment of RJ45 Communication Connector

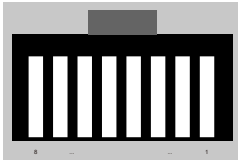
Connector	Pin	Signal	Description
	1	TD+	Send data
	2	TD-	Send data
	3	RD+	Receive data
	4	–	N.C. (Pins denoted as N.C. do not connect to any signal)
	5	–	N.C. (Pins denoted as N.C. do not connect to any signal)
	6	RD-	Receive data
	7	–	N.C. (Pins denoted as N.C. do not connect to any signal)
	8	–	N.C. (Pins denoted as N.C. do not connect to any signal)
	Housing	–	Shield

■ Communication Cable

YASKAWA recommends using EtherCAT® dedicated Cat5e or better communication cables.

■ Network Termination

If the drive is the last node in the network, network termination is automatically realized by the ASIC of the Communication Option card.

5 Mechanical & Electrical Installation

◆ Safety Precautions

▲ DANGER *Electrical Shock Hazard. Do not examine, connect, or disconnect wiring on an energized drive. Before servicing, disconnect all power to the equipment and wait for the time specified on the warning label at a minimum. The internal capacitor stays charged after the drive is de-energized. The charge indicator LED extinguishes when the DC bus voltage decreases below 50 Vdc. When all indicators are OFF, remove the covers before measuring for dangerous voltages to make sure that the drive is safe. Failure to obey will cause death or serious injury.*

▲ WARNING *Electrical Shock Hazard. Do not operate equipment when covers are missing. Some figures in this section include drives without covers or safety shields to more clearly show the inside of the drive. Replace covers and shields before operation. Use drives only as specified by the instructions. Failure to obey can cause death or serious injury.*

▲ WARNING *Electrical Shock Hazard. Do not work on the drive or around the drive while wearing loose clothing or jewelry. Tighten loose clothing and remove all metal objects such as watches or rings. Failure to obey can cause death or serious injury.*

▲ WARNING *Electrical Shock Hazard. Do not remove covers or touch circuit boards while the drive is energized. Failure to obey can cause death or serious injury.*

▲ WARNING *Electrical Shock Hazard. Only let authorized persons install, wire, maintain, examine, replace parts, and repair the drive. Failure to obey can cause death or serious injury.*

▲ WARNING *Electrical Shock Hazard. Do not make changes to the drive body or drive circuitry. Failure to obey can cause death or serious injury and will void warranty. Yaskawa is not responsible for changes to the product made by the user.*

⚠ WARNING *Fire Hazard. Tighten all terminal screws to the correct tightening torque. Connections that are too loose or too tight can cause incorrect operation and damage to the drive. Incorrect connections can also cause death or serious injury from fire.*

⚠ CAUTION *Crush Hazard. Do not hold the drive by the front cover or terminal cover. Tighten the screws correctly before moving the drive. Failure to obey can cause minor to moderate injury.*

NOTICE *Observe correct electrostatic discharge (ESD) procedures when touching the drive. Failure to obey can cause ESD damage to the drive circuitry.*

NOTICE *Do not lift the drive with the cover removed. Failure to obey can cause damage to the drive board and terminal block.*

NOTICE *Do not use unshielded wire for control wiring. Use shielded, twisted-pair wires and ground the shield to the ground terminal of the drive. Failure to obey can cause electrical interference and unsatisfactory system performance.*

NOTICE *Do not change the drive circuitry. Failure to obey can cause damage to the drive and will void warranty. Yaskawa is not responsible for modifications of the product made by the user.*

NOTICE *Make sure that all connections are correct after you install the drive and connecting peripheral devices. Failure to obey can cause damage to the drive.*

◆ Preconditions for Installing the Option Card

Prior to installing the Communication Option Card, wire the AC drive or regenerative unit and connect to the drive terminals. For more information on wiring and connecting the inverter drive or regenerative unit, refer to the manual packaged with the AC drive or regenerative unit.

Verify that the AC drive or regenerative unit runs normally without the option installed.

■ Tools Required

A Phillips screwdriver PH1(#1) or PH2(#2) is required to install the Communication Option card.

Note:

Tools required to prepare communication network cables for wiring are not listed in this manual.

◆ Installing the Option on a A1000, D1000, R1000, or U1000

1. Turn off the power. Wait until the CHARGE LED turns off and then remove the cover. Refer to the drive manual for direction on removing the front cover.
2. Plug the option card (E) to the CN5-A connector (C).
Fieldbus option cards must always be plugged into CN5-A connector.
3. Connect the ground wire (F) to option card and fix with screw (1).
Select shortest possible cable for ground connection.
4. Fix option card to the drive with screw (2) additionally. Connect the ground wire (F) to drive ground terminal (D).

Note:

There are only two screw holes on the drive for ground terminals. If three different option cards are connected, two of the ground wires will need to share the same ground terminal.

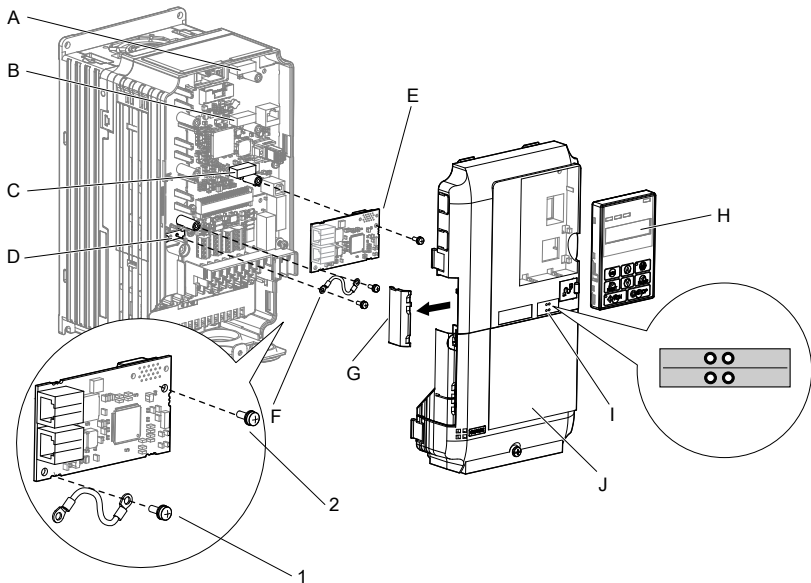

- | | |
|--|---|
| A - Connector CN5-C | F - Ground wire |
| B - Connector CN5-B | G - Opening for cable lines (use cutter to create the opening) |
| C - Connector CN5-A | H - Operator |
| D - Drive grounding terminal (FE) | I - LED labels |
| E - Option cards | J - Front cover |

Figure 5.1 Installing the Option Card on a A1000, D1000, R1000 or U1000

5. Prepare the RJ45 network cable connectors.

For drives CIMR-Ax2A0004 to 2A0040 and 4A0002 to 4A0023: the network cable should be routed to the outside through the openings at the left side (G) of the front cover. Make sure no sharp edges remain.

For drives 2A0056 to 2A0211, and 4A0031 to 0165: enough space to keep all wiring inside the unit is available.

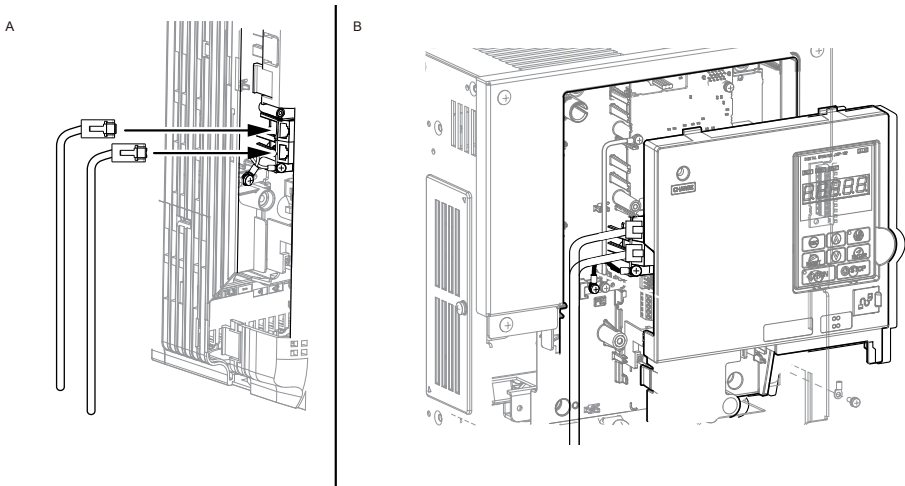

A - Opening for network cables (CIMR-Ax2A0004 to 2A0040, 4A0002 to 4A0023)

B - Space for wiring (CIMR-Ax2A0056 to 2A0211, 4A0031 to 4A0165)

Figure 5.2 Network Cable Routing

6. Plug in the RJ45 network cable connector to the option.
7. Reinstall the front cover back onto the drive as it was before.
8. Attach the LED label (I) as shown in [Figure 5.1](#).
9. Switch on the drive power supply.

◆ **Installing the Option on a V1000**

1. Turn off the power. Wait until the CHARGE LED turns off and then remove the cover.
2. Remove the front cover. Refer to the drive manual for direction on removing the front cover.

Note:

The original front cover may be discarded because it will be replaced by the cover of the Communication Option card.

- Remove the bottom cover and connect the Communication Option ground wire to the ground terminal.

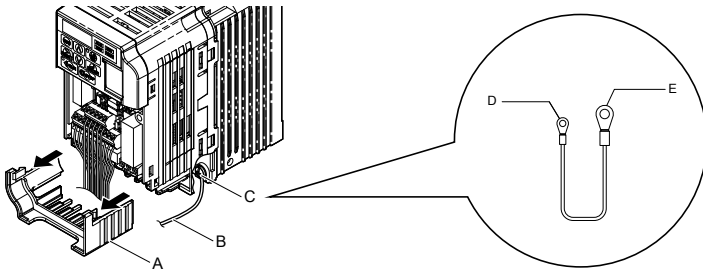

A - Bottom Cover

B - Ground Cable

C - Wire

D - Communication Option card connection (screw size: M3)

E - Drive-side connection (screw size: M3.5 to M6)

Figure 5.3 Connect Ground Wire

Select shortest possible cable for ground connection.

- Re-attach the bottom cover.
- Connect the Communication Option card to the drive. Properly secure the tabs on the left and right side of the Communication Option card to the drive case.

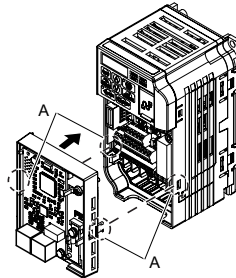

A - Tabs should line up

Figure 5.4 Attach Communication Option Card

- Connect the ground wire to the Communication Option card.
When wiring the Communication Option card, pass the ground wire through the inside of the drive bottom cover, then pass the ground wire into the through-hole for the ground wire at the front of the Communication Option card.

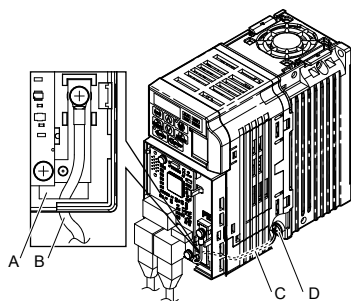

A - Through-hole for ground wire
 B - Ground wire

C - Pass ground wire through the bottom cover of the drive
 D - Drive ground terminal

Figure 5.5 Connect Ground Wire

7. Connect the communication wire to the Communication Option card modular connector.
8. Attach the cover to the front of the Communication Option card.
9. Switch on the drive power supply.

◆ **Installing the Option on a GA800, or GA700**

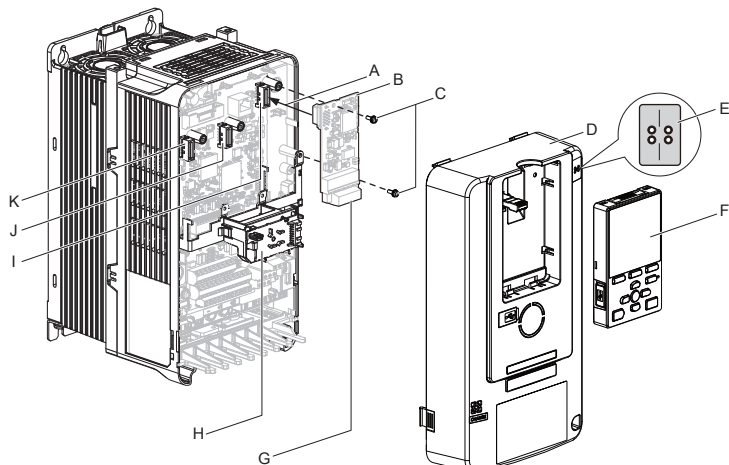

A - Insertion for CN5 connector
 B - Option card
 C - Screws (included)
 D - Drive front cover
 E - LED label
 F - Keypad

G - Option terminal block (CN1)
 H - LED Status Ring board
 I - Connector CN5-A
 J - Connector CN5-B (Not for communication option installation)
 K - Connector CN5-C (Not for communication option installation)

Figure 5.6 Drive Components with Option Card

The procedures for removing and re-attaching the front cover of the drives, and for removing the LED Status Ring board, differ by model. For detailed information please refer to the Technical Manual of the inverter drive. Communication option cards can only be inserted into the CN5-A connector located on the drive control board.

1. Affix the LED label (E) in the appropriate position on the drive front cover (D).

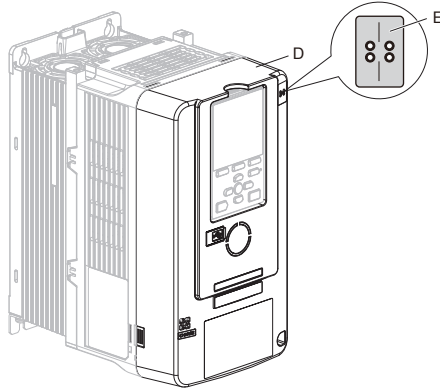

Figure 5.7 Affix the LED Label

2. Turn off the power. Wait until the CHARGE LED turns off and then remove the cover. Refer to the drive manual for direction on removing the front cover.
3. Move the keypad connector to the holder on the drive after removing the keypad and before removing the front cover. Insert the keypad connector tab into the holder when installing the keypad connector to the holder.

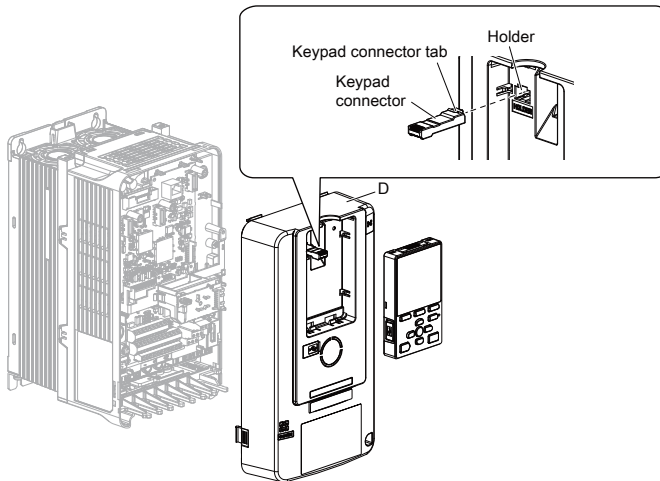

Figure 5.8 Remove the Front Cover and Keypad

- Carefully remove the LED Status Ring board (H) and place it on the right side of the drive using the temporary placement holes. Do not remove the LED Status Ring board cable connector.

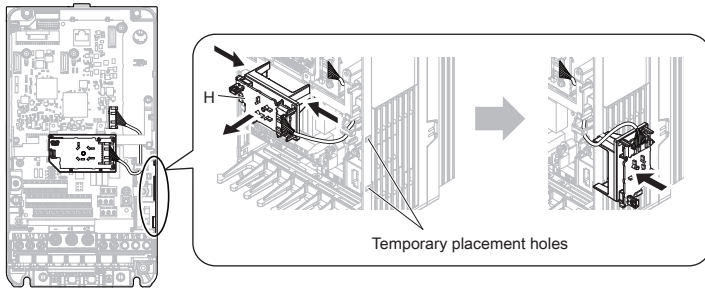

Figure 5.9 Remove the LED Status Ring Board

- Insert the option card (B) into the CN5-A connector (I) on the drive and fasten it into place using the included screws (C). Tighten both screws to 0.5 to 0.6 Nm (4.4 to 5.3 in. lbs).

Note:

Installing the option card on a drive requires only two screws and does not require a ground wire. The option package ships with three screws and a ground wire for installation on other drive series. Do not use the ground wire or the extra screw.

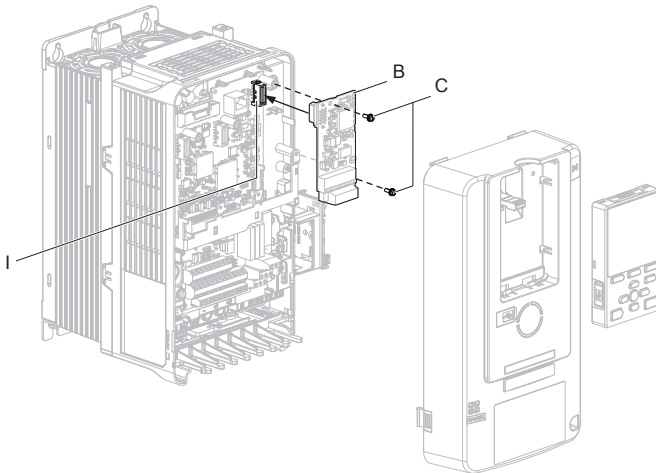

Figure 5.10 Insert the Option Card

- Firmly connect the communication cable to option terminal block. Install communications cables apart from main-circuit wiring and other electrical and power lines. Ensure the cable end is firmly connected.
- Reattach and secure the LED Status Ring board (H). Use the open space provided inside the LED Status Ring board to route option wiring. Do not pinch cables between the front cover or the LED Status Ring board and the drive.
- Install the keypad to the drive after replacing the keypad connector and then the keypad connector. At that time, insert the keypad connector tab into the drive.

9. Reattach and secure the front cover of the drive (D) including the keypad (F).

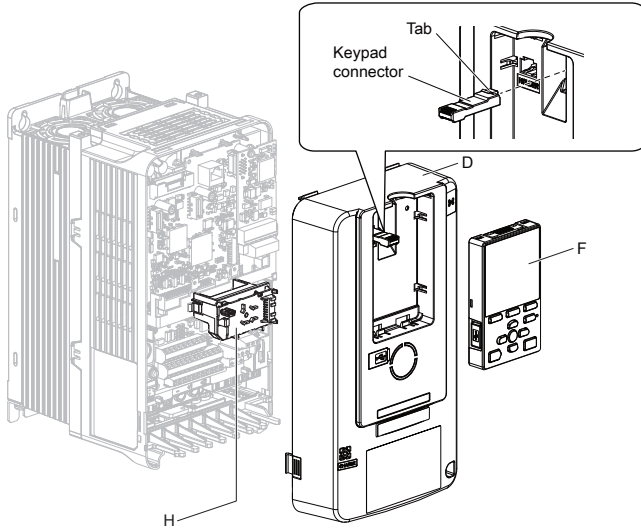

Figure 5.11 Reinstall the Front Cover and Keypad

10. Switch on the drive power supply.

◆ Installing the Option on a GA500

If you want to install the option card on a GA500 AC drive, you must use the Option Card Mounting Kit (Model: JOHB-GA500). The installation procedure is described in the manual that is shipped with that option.

Communication option cards can only be inserted into the **CN5-A** connector located on the drive control board.

◆ Installing the Option on a Q2A

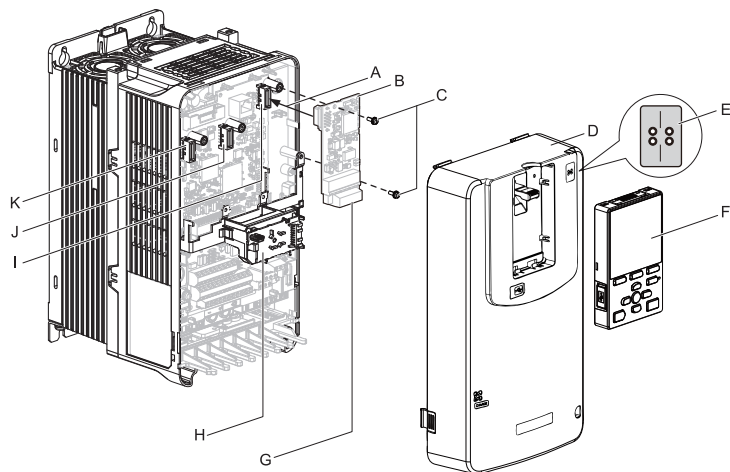

A - Insertion for CN5 connector

B - Option card

C - Screws (included)

D - Drive front cover

E - LED label

F - Keypad

G - Option terminal block (CN1)

H - USB port board

I - Connector CN5-A

J - Connector CN5-B (Not for communication option installation)

K - Connector CN5-C (Not for communication option installation)

Figure 5.12 Q2A Components with Option Card

The procedures for removing and re-attaching the front cover of the inverter drives, and for removing the USB port board, differ by model. For detailed information please refer to the Technical Manual of the inverter drive. Communication option cards can only be inserted into the CN5-A connector located on the drive control board.

1. Affix the LED label (E) in the appropriate position on the drive front cover (D).

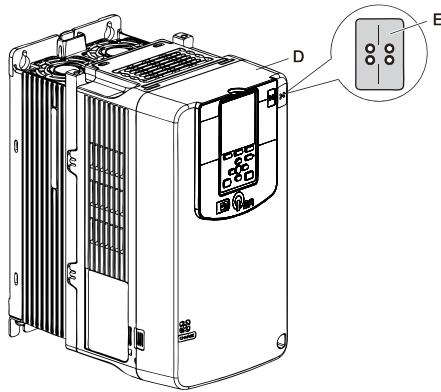

Figure 5.13 Affix the LED Label

2. Turn off the power. Wait until the CHARGE LED turns off and then remove the cover. Refer to the drive manual for direction on removing the front cover.
3. Move the keypad connector to the holder on the drive after removing the keypad and before removing the front cover. Insert the keypad connector tab into the holder when installing the keypad connector to the holder.

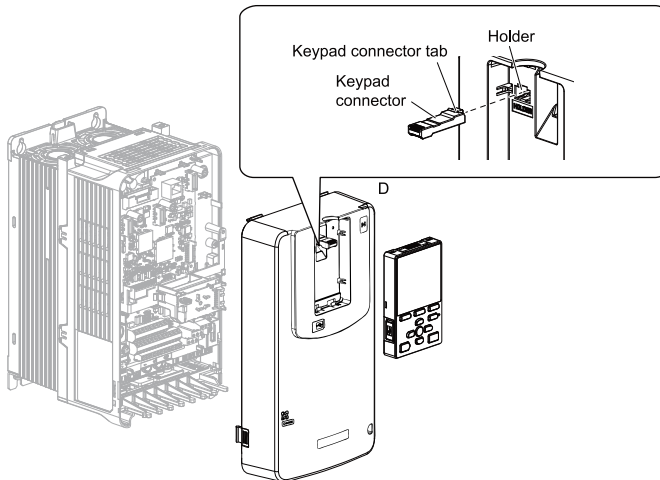

Figure 5.14 Remove the Front Cover and Keypad

- Carefully remove the USB port board (H) and place it on the right side of the drive using the temporary placement holes. Do not remove the USB port board cable connector.

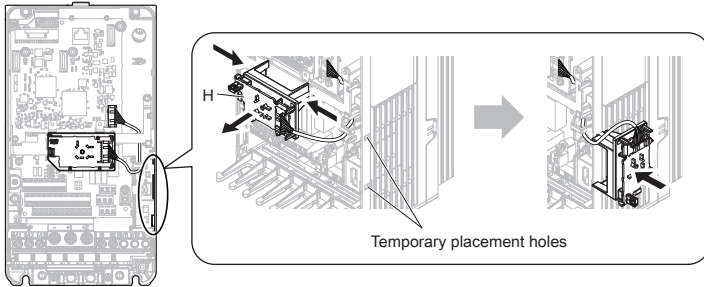

Figure 5.15 Remove the USB Port Board

- Insert the option card (B) into the CN5-A connector (I) on the drive and fasten it into place using the included screws (C). Tighten both screws to 0.5 to 0.6 Nm (4.4 to 5.3 in. lbs).

Note:

Installing the option card on a Q2A drive requires only two screws and does not require a ground wire. The option package ships with three screws and a ground wire for installation on other drive series. Do not use the ground wire or the extra screw.

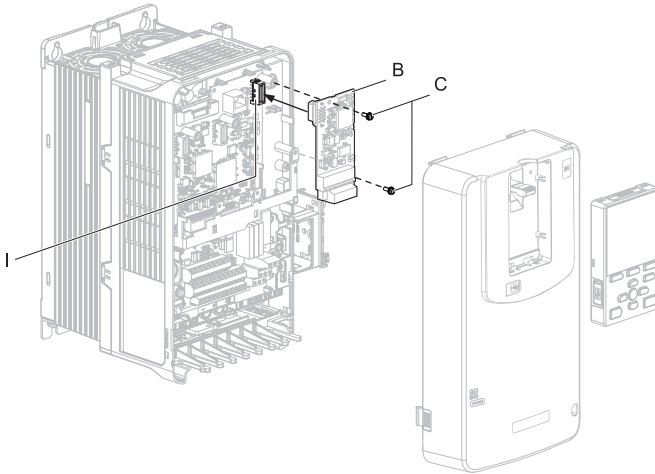

Figure 5.16 Insert the Option Card

- Firmly connect the communication cable to option terminal block. Install communications cables apart from main-circuit wiring and other electrical and power lines. Ensure the cable end is firmly connected.
- Reattach and secure the USB port board (H). Use the open space provided inside the USB port board to route option wiring. Do not pinch cables between the front cover or the USB port board and the drive.
- Install the keypad to the drive after replacing the keypad connector and then the keypad connector. At that time, insert the keypad connector tab into the drive.

9. Reattach and secure the front cover of the drive (D) including the keypad (F).

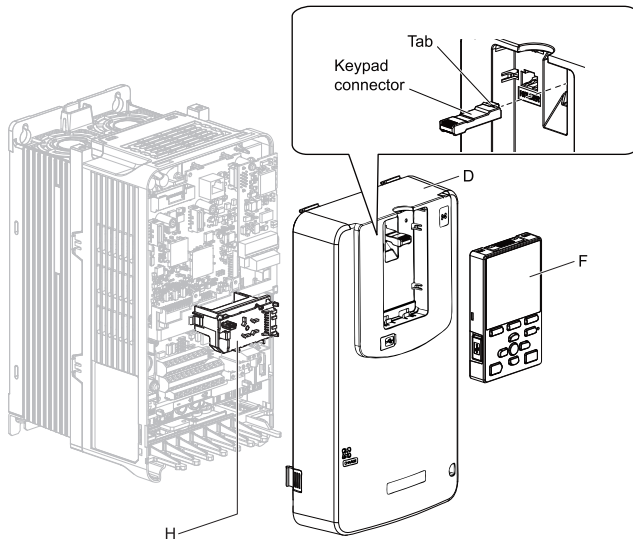

Figure 5.17 Reinstall the Front Cover and Keypad

10. Switch on the drive power supply.

◆ Installing the Option on a Q2V

If you want to install the option card on a Q2V AC drive, you must use the Option Card Mounting Kit (Model: JOHB-Q2V). The installation procedure is described in the manual that is shipped with that option.

Communication option cards can only be inserted into the **CN5-A** connector located on the drive control board.

◆ ESI File

For easy network implementation of drives equipped with a Communication Option card, the ESI file can be obtained from these sources:

- Europe:
<http://www.yaskawa.eu.com>
- Japan:
<http://www.e-mechatronics.com>
- USA:
<http://www.yaskawa.com>

For other areas, and when using Q2A or Q2V AC drives, contact your sales representative.

6 EtherCAT Option Related Drive Parameters

◆ Parameters for A1000, D1000, R1000, U1000, GA800, GA700, GA500, CR700, V1000

Some drive parameters have influence on some functions of the communication option card. Check these parameters before starting network communications.

Table 6.1 Parameter Settings

No.	Name	Description	Default
b1-01 *1	Frequency Reference Selection	Selects the frequency reference input source 0: Operator - Digital preset speed d1-01 to d1-17 1: Terminals - Analog input terminals 2: MEMOBUS/Modbus communications 3: Option card 4: Pulse Input (Terminal RP)	*6
b1-02 *1	Run Command Selection	Selects the run command input source 0: Digital Operator - RUN and STOP keys 1: Digital input terminals Sx 2: MEMOBUS/Modbus communications 3: Option card	1
E2-04, E4-04, E5-04, E9-09 *2	Motor Poles	Set the number of motor poles described on the motor nameplate. Relevant for DSP402. 2 to 48	4
F6-01	Operation Selection after Communications Error	Determines drive response when a bUS error is detected during communications with the EtherCAT Option 0: Ramp to Stop 1: Coast to Stop 2: Fast-Stop 3: Alarm Only *3	1
F6-02	External Fault Detection Conditions (EF0)	Sets the condition for external fault detection (EF0) 0: Always detected 1: Detected only during operation	0
F6-03	Stopping Method for External Fault from Communication Option Board	Determines drive response for external fault input (EF0) detection during EtherCAT communication 0: Ramp to Stop 1: Coast to Stop 2: Fast-Stop 3: Alarm Only	1
F6-06 *4	Torque Reference/Torque Limit selection from Communications Option	0: Torque reference/torque limit via network communications are disabled. 1: Torque reference/torque limit via network communications are enabled. *5	0
F6-07	NetRef/ComRef Selection Function	0: Multi-step speed reference disabled 1: Multi-step speed reference allowed	0

No.	Name	Description	Default
F6-08	Reset Communication Related Parameters	Determines if communication-related parameters are set back to their original default values when the drive is initialized. 0: Do not reset F6-xx and F7-xx parameters when the drive is initialized using parameter A1-03. 1: Reset F6-xx and F7-xx parameters when the drive is initialized using parameter A1-03. Note: Setting this parameter does not affect communication-related parameters. Setting this parameter only determines if communication-related parameters (F6-xx and F7-xx) are also reset when A1-03 is used to initialize the drive.	0
o1-03 *7	Digital Operator Display Selection	Sets the units to display the frequency reference and output frequency. 0: 0.01 Hz 1: 0.01% (100% = E1-04) 2: r/min (enter the number of motor poles to E2-04/E4-04/E5-04). Relevant for DSP402. 3: User defined by parameters o1-10 and o1-11	*6

- *1 To start and stop the drive from an EtherCAT® master device using serial communications, set b1-02 to 3. To control the frequency reference of the drive via the master device, set b1-01 to 3.
- *2 It's necessary to set up the number of motor poles when the Drive Profile DSP402 objects are used. Also refer to *7
- *3 If set to 3, then the drive will continue to operate when an EF0 fault is detected. Take proper safety measures, such as installing an emergency stop switch.
- *4 This parameter might not appear in certain drives. Furthermore its availability is limited to depending on the control mode selection. For details refer to the technical manual for the drive the option card is used with.
- *5 If the drive is set to receive the torque reference/limit from the network (F6-06 = 1) make sure the value is set appropriately by the controller. If no torque reference/limit value is entered the motor will not produce torque.
- *6 The default value depends on the drive used and/or the drive software version. For details refer to the technical manual for the drive.
- *7 Changing o1-03 changes the units for input object 2010 (Hex) (frequency reference), output object 2110 (Hex) (output frequency) and 2200 (Hex) (motor speed). Furthermore o1-03 must be set to 2 and the number of motor poles must be set to the correct value in order to use the Drive Profile DSP402.

◆ Parameters for Q2A, Q2V

Some drive parameters have influence on some functions of the communication option card. Check these parameters before starting network communications.

Table 6.2 Parameter Settings

No.	Name	Description	Default
b1-01 *1	Freq. Ref. Sel. 1	Sets the input method for the frequency reference. 0: Keypad 1: Analog Input 2: Modbus 3: Option PCB 4: Pulse Train Input	*6
b1-02 *1	Run Comm. Sel 1	Sets the input method for the Run command. 0: Keypad 1: Analog Input 2: Modbus 3: Option PCB	1

6 EtherCAT Option Related Drive Parameters

No.	Name	Description	Default
E2-04, E4-04, E5-04, E9-09 <i>*2</i>	Motor Pole Count	Sets the number of motor poles. 2 to 48	4
F6-01	Comm.Error Selection	Sets the method to stop the motor or let the motor continue operating when the drive detects a <i>bUS [Option Communication Error]</i> . 0: Ramp->Stop 1: Coast->Stop 2: Fast-Stop (C1-09) 3: Alarm Only <i>*3</i> 4: AL-Run at d1-04 5: AL-Ramp Stop	1
F6-02	Comm Ext Flt Detect (EF0)	Sets when the drive will detect <i>EF0 [Option Card External Fault]</i> is detected. 0: Always Detected 1: Detect@RUN Only	0
F6-03	Comm Ext Flt Select (EF0)	Determines drive response for external fault input (EF0) detection during EtherCAT communication 0: Ramp->Stop 1: Coast->Stop 2: Fast-Stop (C1-09) 3: Alarm Only	1
F6-06 <i>*4</i>	Trq Ref/Lim Comms	Sets the function that enables and disables the torque reference and torque limit received from the communication option. 0: Disabled. 1: Enabled. <i>*5</i>	0
F6-07	Multi-Ref@NetRef/ ComRef	Sets the function that enables and disables the multi-step speed reference when the frequency reference source is NetRef or ComRef (communication option card or Modbus communications). 0: Disable MultiStep References 1: Enable MultiStep References	0
F6-08	Comm Par RST@Initialize	Sets the function to initialize <i>F6-xx and F7-xx parameters</i> when the drive is initialized with <i>A1-03 [Init Parameters]</i> . 0: Retain Pars - No Reset 1: Factory Default - Reset	0
o1-03 <i>*7</i>	FrqDisplay Unit Selection	Sets the display units for the frequency reference and output frequency. 0: 0.01 Hz 1: 0.01% (100% = E1-04) 2: rpm (Enter the number of motor poles to E2-04/E4-04/E5-04). Relevant for DSP402. 3: User-selected units	<i>*6</i>

*1 To start and stop the drive from an EtherCAT® master device using serial communications, set b1-02 to 3. To control the frequency reference of the drive via the master device, set b1-01 to 3.

*2 E2-04 is necessary to set up when the Drive Profile DSP402 objects are used. Also refer to **7*

- *3 If set to 3, then the drive will continue to operate when an EF0 fault is detected. Take proper safety measures, such as installing an emergency stop switch.
- *4 This parameter might not appear in certain drives. Furthermore its availability is limited to depending on the control mode selection. For details refer to the technical manual for the drive the option card is used with.
- *5 If the drive is set to receive the torque reference/limit from the network (F6-06 = 1) make sure the value is set appropriately by the controller. If no torque reference/limit value is entered the motor will not produce torque.
- *6 The default value depends on the drive used and/or the drive software version. For details refer to the technical manual for the drive.
- *7 Changing o1-03 changes the units for input object 2010 (Hex) (frequency reference), output object 2110 (Hex) (output frequency) and 2200 (Hex) (motor speed). Furthermore o1-03 must be set to 2 and E2-04 must be set to the correct value in order to use the Drive Profile DSP402.

7 Troubleshooting

◆ Communication Option Card Error Codes

If a fault or alarm occurs in the inverter drive or regenerative unit, the fault or alarm will be stored in consecutive sub-indices of object 1003. Additionally an emergency telegram will be sent once.

Index (Hex)	Sub	Content	Acc.	PDO Map.	Data Type	Value (Range)
1003	0	Number of errors	RW	No	UNS8	00 (Hex) (00 - FF (Hex))
1003	1	Standard error field (Emergency error code)	RO	No	UNS32	0000 (Hex) (0000 - FFB8 (Hex))

Table 7.1 Emergency Telegram Specification

Byte	0	1	2	3	4	5	6	7
Content	Emergency Error Code			Error register object 1001 (Hex) = 1	Manufacturer specific error info. Not used. Set to zero.			

◆ Emergency Error Codes

Error Code (Hex)	Meaning	Drive Display	Value of MEMOBUS/ Modbus Address 0080 (Hex)
0000	No error	No error	00
5450	DC Fuse Blowout	FUd	01
3220	DC bus undervoltage	Uv1	02
5200	Ctrl Power Supply Voltage Fault	Uv2	03
3221	SoftCharge Bypass Circuit Fault	Uv3	04
2340	Out Short Circuit or IGBT Fault	SC	05
2330	Ground Fault	GF	06

Error Code (Hex)	Meaning	Drive Display	Value of MEMOBUS/Modbus Address 0080 (Hex)
2220	Overcurrent	oC	07
3210	DC Bus Overvoltage	ov	08
4280	Heatsink Overheat	oH	09
4210	Heatsink Overheat	oH1	0A
2310	Motor Overload	oL1	0B
2221	Drive Overloaded	oL2	0C
2311	Overtorque Detection 1	oL3	0D
2312	Overtorque Detection 2	oL4	0E
5420	Dynamic Braking Transistor	rr	0F
4410	Braking Resistor Overheat	rH	10
5441	External Fault (terminal S3)	EF3	11
5442	External Fault (terminal S4)	EF4	12
5443	External Fault (terminal S5)	EF5	13
5444	External Fault (terminal S6)	EF6	14
5445	External Fault (terminal S7)	EF7	15
5480	External Fault (terminal S8)	EF8	16
FF01	Internal Fan Fault	FAn	17
7180	Overspeed	oS	18
8321	Speed Deviation	dEv	19
7305	PG Disconnect	PGo	1A
3130	Input Phase Loss	PF	1B
3300	Output Phase Loss	LF	1C
FF02	Motor Overheat Alarm (PTC Input)	oH3	1D
5300	Keypad Connection Fault	oPr	1E
5530	EEPROM Write Error	Err	1F
4310	Motor Overheat Fault (PTC Input)	oH4	20
FF03	MEMOBUS/Modbus Communication Fault	CE	21
FF04	Option Communication Error	bUS	22
FF05	Control Fault	CF	25
8313	Zero Servo Fault	SvE	26

Error Code (Hex)	Meaning	Drive Display	Value of MEMOBUS/ Modbus Address 0080 (Hex)
5481	Option Card External Fault	EF0	27
FF06	PID Feedback Loss	FbL	28
FF07	Undertorque Detection 1	UL3	29
FF08	Undertorque Detection 2	UL4	2A
FF09	High Slip Braking oL	oL7	2B
FF0A	External Fault 9	EF9	2C
FF0B	External Fault 10	EF10	2D
FF0C	External Fault 11	EF11	2E
FF0D	External Fault 12	EF12	2F
6000	Hardware Fault	oFx	30
FF0E	Z Pulse Fault	dv1	32
FF0F	Z Pulse Noise Fault Detection	dv2	33
FF10	Inversion Detection	dv3	34
FF11	Inversion Prevention Detection	dv4	35
FF12	Output Current Imbalance	LF2	36
FF13	Pull-Out Detection	STPo	37
FF14	PG Hardware Fault	PGoH	38
FF15	MECHATROLINK Watchdog Timer Err	E5	39
FF16	Too Many Speed Search Restarts	SEr	3B
FF17	Reserved	CASEFAL1	3C
FF18	Reserved	CASEFAL2	3D
FF19	Reserved	CASEFAL3	3E
FF1A	Reserved	CASEFAL4	3F
FF1B	Reserved	CASEFAL5	40
FF1C	Excessive PID Feedback	FbH	41
FF1D	External Fault (terminal S1)	EF1	42
FF1E	External Fault (terminal S2)	EF2	43
FF1F	Mechanical Weakening Detection 1	oL5	44
FF20	Mechanical Weakening Detection 2	UL5	45
FF21	Current Offset Fault	CoF	46

Error Code (Hex)	Meaning	Drive Display	Value of MEMOBUS/Modbus Address 0080 (Hex)
FF22	PLC Detection Error 1	PE1	47
FF23	PLC Detection Error 2	PE2	48
FF24	DriveWorksEZ Fault	dWFL	49
6301	Error during object content selection	-	-
FF25	EEPROM Memory DWEZ Data Error	dWF1	4A
FF26	DriveWorksEZ Fault 2	dWF2	4B
FF27	DriveWorksEZ Fault 3	dWF3	4C
FF28	Output Voltage Detection Fault	voF	4D
FF29	Braking Resistor Fault	rF	4E
FF2A	BrakingTransistor Overload Fault	boL	4F
FF2B	Motor Overheat (NTC Input)	oH5	50
FF2C	LSo Fault	LSo	51
FF2D	Node Setup Error	nSE	52
FF2E	Thermistor Disconnect	THo	53
FF2F	Overacceleration Detection	dv6	54
FF30	Motor Contactor Response Error	SE1	55
FF31	Starting Current Error	SE2	56
FF32	Output Current Error	SE3	57
FF33	Brake Response Error	SE4	58
FF34	Speed Reference Missing	FrL	59
FF35	Polarity Judge Timeout	dV7	5B
FF36	Ground Fault	GF	5C
FF37	Output Phase Loss 3	LF3	5F
FF38	Current Imbalance	UnbC	60
FF39	Gate Drive Board Power Supply Voltage Low	Uv4	61
FF3A	Power Supply Undervoltage	Auv	66
FF3B	Power Supply Overvoltage	Aov	67
FF3C	Power Supply Frequency Fault	Fdv	68
FF3D	Phase Order Detection Fault	SrC	69
FF3E	Power Supply Undervoltage Pre-Alarm	PAUv	6B

Error Code (Hex)	Meaning	Drive Display	Value of MEMOBUS/ Modbus Address 0080 (Hex)
FF3F	AC Fuse Blowout	FUA	70
FF40	Resonance Detection	vrE	71
FF41	Control Circuit Error	CPF00	81
FF42	Control Circuit Error	CPF01	82
FF43	A/D Conversion Failure	CPF02	83
FF44	PWM Motor Failure	CPF03	84
FF45	Control Circuit Error	CPF06	87
FF46	Terminal Board Connection Error	CPF07	88
FF47	EEPROM Serial Communications Error	CPF08	89
FF48	RAM Fault	CPF11	8C
FF49	FLASH Memory Fault	CPF12	8D
FF4A	Watchdog Circuit Exception	CPF13	8E
FF4B	Control Circuit Fault	CPF14	8F
FF4C	Clock Fault	CPF16	91
FF4D	Timing Fault	CPF17	92
FF4E	Control Circuit Fault	CPF18	93
FF4F	Control Circuit Fault	CPF19	94
FF50	Hardware Fault (at power ON)	CPF20	95
FF51	Hardware Fault (after communication start up)	CPF21	96
FF52	A/D Conversion Failure	CPF22	97
FF53	PWM Feedback Fault	CPF23	98
FF54	Drive Capacity Signal Fault	CPF24	99
FF55	Terminal Board not Connected	CPF25	9A
FF56	ASIC BB Circuit Error	CPF26	9B
FF57	ASIC PWM Setting Register Error	CPF27	9C
FF58	ASIC PWM Pattern Error	CPF28	9D
FF59	ASIC On-delay Error	CPF29	9E
FF5A	ASIC BB ON Error	CPF30	9F
FF5B	ASIC Code Error	CPF31	A0
FF5C	ASIC Start-up Error	CPF32	A1

Error Code (Hex)	Meaning	Drive Display	Value of MEMOBUS/Modbus Address 0080 (Hex)
FF5D	Watchdog Circuit Exception Circuit Fault	CPF33	A2
FF5E	ASIC Power, Clock Error	CPF34	A3
FF5F	External A/D Conversion Failure	CPF35	A4
FF60	ASIC Reception Error	CPF36	A5
FF61	ASIC Reception Error	CPF37	A6
FF62	EEPROM Motor Failure	CPF38	A7
FF63	Control Circuit Error	CPF40	A9
FF64	Control Circuit Error	CPF41	AA
FF65	Control Circuit Error	CPF42	AB
FF66	Control Circuit Error	CPF43	AC
FF67	Control Circuit Error	CPF44	AD
FF68	Control Circuit Error	CPF45	AE
FF69	Option Card Connection Error at Option Port CN5-A	oFA00	101
FF6A	Option Card Fault at Option Port CN5-A	oFA01	102
FF6B	Option Card Fault at Option Port CN5-A	oFA02	103
FF6C	Option Card Error Occurred at Option Port CN5-A	oFA03	104
FF6D	Option Card Error Occurred at Option Port CN5-A	oFA04	105
FF6E	Option Card Error Occurred at Option Port CN5-A	oFA05	106
FF6F	Option Card Error Occurred at Option Port CN5-A	oFA06	107
FF70	Option Card Error Occurred at Option Port CN5-A	oFA10	111
FF71	Option Card Error Occurred at Option Port CN5-A	oFA11	112
FF72	Option Card Error Occurred at Option Port CN5-A	oFA12	113
FF73	Option Card Error Occurred at Option Port CN5-A	oFA13	114
FF74	Option Card Error Occurred at Option Port CN5-A	oFA14	115
FF75	Option Card Error Occurred at Option Port CN5-A	oFA15	116
FF76	Option Card Error Occurred at Option Port CN5-A	oFA16	117
FF77	Option Card Error Occurred at Option Port CN5-A	oFA17	118
FF78	Comm. ID Error	oFA30	131
FF79	Model Code Error	oFA31	132
FF7A	Checksum Error	oFA32	133

Error Code (Hex)	Meaning	Drive Display	Value of MEMOBUS/ Modbus Address 0080 (Hex)
FF7B	Comm. option timeout waiting for response	oFA33	134
FF7C	MEMOBUS/Modbus communications timeout	oFA34	135
FF7D	Drive timeout waiting for response	oFA35	136
FF7E	CI Check Error	oFA36	137
FF7F	Drive timeout waiting for response	oFA37	138
FF80	Control Command Selection Error	oFA38	139
FF81	Drive timeout waiting for response	oFA39	13A
FF82	Control Response Selection 1 Error	oFA40	13B
FF83	Drive timeout waiting for response	oFA41	13C
FF84	Control Response Selection 2 Error	oFA42	13D
FF85	Drive timeout waiting for response	oFA43	13E
FF86	Option Card Fault at Option Port CN5-B	oFb00	201
FF87	Option Card Fault at Option Port CN5-B	oFb01	202
FF88	Option Card Fault at Option Port CN5-B	oFb02	203
FF89	Option Card Fault at Option Port CN5-B	oFb05	206
FF8A	Option Card Fault at Option Port CN5-B	oFb06	207
FF8B	Option Card Fault at Option Port CN5-B	oFb10	211
FF8C	Option Card Error Occurred at Option Port CN5-B	oFb11	212
FF8D	Option Card Error Occurred at Option Port CN5-B	oFb12	213
FF8E	Option Card Error Occurred at Option Port CN5-B	oFb13	214
FF8F	Option Card Error Occurred at Option Port CN5-B	oFb14	215
FF90	Option Card Error Occurred at Option Port CN5-B	oFb15	216
FF91	Option Card Error Occurred at Option Port CN5-B	oFb16	217
FF92	Option Card Error Occurred at Option Port CN5-B	oFb17	218
FF93	Comm. ID Error	oFb30	231
FF94	Model Code Error	oFb31	232
FF95	Checksum Error	oFb32	233
FF96	Comm. option timeout waiting for response	oFb33	234
FF97	MEMOBUS/Modbus communications timeout	oFb34	235
FF98	Drive timeout waiting for response	oFb35	236

Error Code (Hex)	Meaning	Drive Display	Value of MEMOBUS/Modbus Address 0080 (Hex)
FF99	CI Check Error	oFb36	237
FF9A	Drive timeout waiting for response	oFb37	238
FF9B	Control Command Selection Error	oFb38	239
FF9C	Drive timeout waiting for response	oFb39	23A
FF9D	Control Response Selection 1 Error	oFb40	23B
FF9E	Drive timeout waiting for response	oFb41	23C
FF9F	Control Response Selection 2 Error	oFb42	23D
FFA0	Drive timeout waiting for response	oFb43	23E
FFA1	Option Card Connection Error at Option Port CN5-C	oFC00	301
FFA2	Option Card Fault at Option Port CN5-C	oFC01	302
FFA3	Option Card Fault at Option Port CN5-C	oFC02	303
FFA4	A/D Conversion Error	oFC05	306
FFA5	Option Response Error	oFC06	307
FFA6	RAM Fault	oFC10	311
FFA7	Option Card Error Occurred at Option Port CN5-C	oFC11	312
FFA8	Option Card Error Occurred at Option Port CN5-C	oFC12	313
FFA9	Option Card Error Occurred at Option Port CN5-C	oFC13	314
FFAA	Option Card Error Occurred at Option Port CN5-C	oFC14	315
FFAB	Option Card Error Occurred at Option Port CN5-C	oFC15	316
FFAC	Option Card Error Occurred at Option Port CN5-C	oFC16	317
FFAD	Option Card Error Occurred at Option Port CN5-C	oFC17	318
FFAE	Option Card Error Occurred at Option Port	oFC50	351
FFAF	Option Card Error Occurred at Option Port	oFC51	352
FFB0	Option Card Error Occurred at Option Port	oFC52	353
FFB1	Option Card Error Occurred at Option Port	oFC53	354
FFB2	Option Card Error Occurred at Option Port	oFC54	355
FFB3	Option Card Error Occurred at Option Port	oFC55	356
FFB4	Damping Resistor Overheat	doH	408
FFB5	Snubber Discharge Resistor Overheat	SoH	409
FFB6	Internal Resistance Fault	Srr	40A

Error Code (Hex)	Meaning	Drive Display	Value of MEMOBUS/Modbus Address 0080 (Hex)
FFB7	Safety Circuit Fault	SCF	40F
FFB8	Drive Cooling Fan Failure	FAn1	413
FFC0	Comparator 1 Limit Error	CP1	414
FFC1	Comparator 2 Limit Error	CP2	415
FFC2	Bluetooth Communication Fault	bCE	416
FFC3	Communication Error 1	dCE1	41A
FFC4	Communication Error 2	dCE2	41B
FFC5	Overcurrent 2	oC2	45F

◆ Yaskawa-specific SDO Abort Codes

SDO abort codes are supported as specified in DS301. Additionally the abort codes listed below are implemented.

SDO Abort Code (Hex)	Description
0602 0010	Consecutive MEMOBUS/Modbus Read/Write/Enter commands are send but the wait time between messages is too short.
	A MEMOBUS/Modbus Read or Write Response (2140 (Hex) and 2150 (Hex)) was attempted but no or an incorrect MEMOBUS/Modbus address has been written to object 2040 (Hex) or 2050 (Hex) before.
	A MEMOBUS/Modbus write request has been sent during DC bus under voltage.
0602 0022	Drive Profile DSP402 is used and a value is written to object 6042 (Hex) (v1 Target Velocity) while the drive status is not "Operation Enable".
	Object 2155 (Hex) is tried to be read while the SI-ES3 option is not in "Operational" state.
	A MEMOBUS/Modbus Read or Write command (2040 (Hex) and 2050 (Hex)) was performed with an invalid MEMOBUS/Modbus address.

◆ Fault

This section gives information about some of the causes and possible solutions of faults. You must use the Fault Reset operation to remove the fault before you can operate the drive. Use the information in this table to remove the cause of the fault.

Code	Name	Causes	Possible Solutions
bUS	Option Communication Error	The drive did not receive a signal from the controller.	Correct wiring errors.
		The communications cable wiring is incorrect.	
		There is a short-circuit in the communications cable or the communications cable is not connected.	<ul style="list-style-type: none"> Repair short circuits and connect cables. Replace the defective communications cable.

Code	Name	Causes	Possible Solutions
		Electrical interference caused a communication data error.	<ul style="list-style-type: none"> Examine the control circuit lines, main circuit lines, and ground wiring, and decrease the effects of electrical interference. Make sure that a magnetic contactor is not the source of the electrical interference, then use a Surge Protective Device if necessary. Use only the recommended cables or other shielded line. Ground the shield on the controller side or the drive input power side. Separate the communication wiring from drive power lines, and install a noise filter to the input side of the power supply for communication. Decrease the effects of electrical interference from the controller.
		The option is incorrectly installed to the drive.	Correctly install the option to the drive.
		The option is damaged.	If the fault continues and the wiring is correct, replace the option.
EF0	Option Card External Fault	The communication option received an external fault from the controller.	<ol style="list-style-type: none"> Find the device that caused the external fault and remove the cause. Clear the external fault input from the controller.
		A programming error occurred on the controller side.	Examine the operation of the controller program.
oFA00	Option Not Compatible with Port	The option connected to connector CN5-A is not compatible.	<p>Connect the option to the correct connector.</p> <p>Note: Encoder options are not compatible with connector CN5-A.</p>
oFA01	Option Fault/ Connection Error	The option card connected to connector CN5-A is not compatible.	<ol style="list-style-type: none"> De-energize the drive. Refer to the option card manual and correctly connect the option card to the connector on the drive.
oFA30 to oFA43	Communication Option Card Connection Error (CN5-A)	A fault occurred in the option card.	<ol style="list-style-type: none"> De-energize the drive. Make sure that the option card is correctly connected to the connector. If the problem continues, replace the option card.
oFb00	Option Not Compatible with Port	The option connected to connector CN5-B is not compatible.	<p>Connect the option to the correct connector.</p> <p>Note: DO-A3, AO-A3, PG-B3, and PG-X3 options can connect to connector CN5-B. To connect only one PG option card, use the CN5-C connector.</p>
oFb02	Duplicate Options	The same option cards or the same type of option cards are connected to connectors CN5-A, B, and C.	Connect the option card to the correct connector.

Code	Name	Causes	Possible Solutions
oFC00	Option Not Compatible with Port	The option connected to connector CN5-C is not compatible.	Connect the option to the correct connector. Note: AI-A3, DI-A3, and communication options cannot be connected to the CN5-C connector.
oFC02	Duplicate Options	The same option cards or the same type of option cards are connected to connectors CN5-A, B, and C.	Connect the option card to the correct connector.

◆ Option Board Error Management

This section describes the errors managed by the option board and the linked actions taken.

Option Error	Description	Error Indication	Possible Solution
OP > SAFEOP/ PREOP when Drive running	When an EtherCAT state transition from OP > SAFEOP/ PREOP was made when the drive was in OPERATION enabled.	BUS Error is triggered in drive. Error against drive will be cleared when the next lower to higher EtherCAT state transition is made.	<ul style="list-style-type: none"> Check and correct state machine transitions in control word.

Option Error	Description	Error Indication	Possible Solution
OP > SAFEOP 1. EtherCAT WD time out	If the EtherCAT watchdog time out is enabled (Default in native XML description file) and output data from PLC to the drive isn't updated in time an error will be triggered	BUS Error is triggered in drive. Error against drive will be cleared when the next lower to higher EtherCAT state transition is made.	<ul style="list-style-type: none"> Check network connection (e.g. if cables plugged in at each node). Check telegram timing. Are telegrams sent to the slave the error occurred on?

Option Error	Description	Error Indication	Possible Solution
OP > SAFE_OP 1. Drive FCS error 2. Drive COMID error	<ol style="list-style-type: none"> Drive has detected a Sum check error. Drive has detected a Communication Option ID error. Possible cause: <ol style="list-style-type: none"> Option card system is overloaded. Option card is not properly processing the state. 	<ol style="list-style-type: none"> Drive fault: OFx32 Drive fault: OFx30 	1+2 actions: <ul style="list-style-type: none"> Disable process data OUT sync manager channel. Force EtherCAT state change to SAFE_OP.

Option Error	Description	Error Indication	Possible Solution
OP > SAFE_OP 1. Option card FCS error 2. Option card COMID error	<ol style="list-style-type: none"> Option card has detected a Sum check error. Option card has detected a Communication Option ID error. Possible cause: <ol style="list-style-type: none"> Drive system is overloaded. Drive is not properly processing the state. 	<ol style="list-style-type: none"> Drive fault: OFx32 Drive fault: OFx30 	1+2 actions: <ul style="list-style-type: none"> Disable process data IN sync manager channel. Force EtherCAT state change to SAFE_OP.

Option Error	Description	Error Indication	Possible Solution
Initial power-up sequence not completed within 10 seconds.	Possible cause: <ul style="list-style-type: none"> • Drive is not processing the internal interface protocol. • Drive does not support this communication option card. 	Drive fault: OFx00 Option will log FATAL event record in NVS memory and set ERR LED: solid RED.	Actions: <ul style="list-style-type: none"> • Check drive firmware version. • If drive firmware version is correct, replace option card. • Replace the drive.

Option Error	Description	Error Indication	Possible Solution
I/F proc time out	Option card has not processed any drive system frames in 1000 ms. Possible cause: <ul style="list-style-type: none"> • Drive has stopped serving the internal interface to option card or HW failure. 	Drive fault: OFx00 Option will log FATAL event record in NVS memory and set ERR LED: solid RED.	<ul style="list-style-type: none"> • Force communication state to INIT.

Option Error	Description	Error Indication	Possible Solution
Option ID Error: Power-up sequence copyright string mismatch.	Drive reported invalid copyright string in power-up process.	Drive fault: OFx00 Option will log FATAL event record in NVS memory and set ERR LED: solid RED.	<ul style="list-style-type: none"> • Replace option card.

◆ Minor Faults/Alarms

This section gives information about the causes and possible solutions when a minor fault or alarm occurs. Use the information in this table to remove the cause of the minor fault or alarm.

Code	Name	Causes	Possible Solutions
CALL	Serial Comm Transmission Error	The communications cable wiring is incorrect.	Correct any wiring errors.
		There is a short circuit or the communications cable is not connected.	<ul style="list-style-type: none"> • Repair short circuits and connect cables. • Replace the defective communications cable.
		There was a programming error on the controller side.	Examine communications at start-up and correct programming errors.
		The communications circuitry is damaged.	<ul style="list-style-type: none"> • Do a self-diagnostics check. • If the problem continues, replace the control board or the drive. For information about replacing the control board, contact Yaskawa or your nearest sales representative.
		The termination resistor setting for MEMOBUS/Modbus communications is incorrect.	On the last drive in a MEMOBUS/Modbus network, set DIP switch S2 to the ON position to enable the termination resistor.
EEP	EEPROM Checksum Error	Communication wiring is faulty, there is a short circuit, or something is not connected properly.	Correct any wiring errors.

Code	Name	Causes	Possible Solutions
		EEPROM checksum error.	<ul style="list-style-type: none"> If these errors occur, the object dictionary will be reset to its default values. After the object dictionary has been changed and object dictionary contents are then changed, execute a Store Parameter command (Index = 1010 (Hex)). If the object dictionary has not been changed, execute a Restore Parameter command (Index = 1011 (Hex)).
		Programming error occurred on the controller side.	Check communications at start-up and correct programming errors.
		Communications circuitry is damaged.	<ul style="list-style-type: none"> Perform a self-diagnostics check. If the problem continues, replace either the control board or the entire drive. For instructions on replacing the control board, contact Yaskawa or your nearest sales representative.
		Termination resistor setting for MEMOBUS/Modbus communications is incorrect.	Enable the termination resistor in the last drive in a MEMOBUS/Modbus network by setting DIP switch S2 to the ON position.

8 Disposal

◆ Disposal Instructions

Correctly dispose of the product and packing material as specified by applicable regional, local, and municipal laws and regulations.

◆ WEEE Directive



The wheeled bin symbol on this product, its manual, or its packaging identifies that you must recycle it at the end of its product life.

You must discard the product at an applicable collection point for electrical and electronic equipment (EEE). Do not discard the product with usual waste.

9 Specifications

Item	Specification
Model	SI-ES3 For V1000: SI-ES3/V
Communication Profile	DSP 301 Ver. 4.02 DSP 402 Ver. 1.1 Velocity Mode
Connector	RJ45 connector
Communication Speed	10/100 Mbps
Ambient Temperature	-10 °C to +50 °C
Humidity	up to 95% RH (non-condensing)
Storage Temperature	-20 °C to +60 °C (allowed for short-term transport of the product)
Area of Use	Indoor (free of corrosive gas, airborne particles, etc.)
Altitude	Up to 1000 m

Revision History

Date of Publication	Revision Number	Section	Revised Content
August 2018	A	-	First Edition Contains information for A/V1000, D/R/U1000, GA700, and Q2A.
May 2020	B	All	Updated with new supported AC drives and regenerative units. Updated software versions. Updated descriptions and procedures.
		3	Added "Labels to be Attached to the Product"

EtherCAT Option

Installation Manual

YASKAWA EUROPE GmbH

Hauptstr. 185, 65760 Eschborn,
Germany
Phone: +49-6196-569-500
E-mail: support@yaskawa.eu.com
<http://www.yaskawa.eu.com>

DRIVE CENTER (INVERTER PLANT)

2-13-1, Nishimiyaichi, Yukuhashi,
Fukuoka, 824-8511, Japan
Phone: +81-930-25-2548
Fax: +81-930-25-3431
<http://www.yaskawa.co.jp>

YASKAWA AMERICA, INC.

2121, Norman Drive South,
Waukegan, IL 60085, U.S.A.
Phone: +1-800-YASKAWA (927-
5292) or +1-847-887-7000
Fax: +1-847-887-7310
<http://www.yaskawa.com>

In the event that the end user of this product is to be the military and said product is to be employed in any weapons systems or the manufacture thereof, the export will fall under the relevant regulations as stipulated in the Foreign Exchange and Foreign Trade Regulations. Therefore, be sure to follow all procedures and submit all relevant documentation according to any and all rules, regulations and laws that may apply.

Specifications are subject to change without notice for ongoing product modifications and improvements.



Original instructions

© 2020 YASKAWA Europe GmbH

YASKAWA Europe GmbH

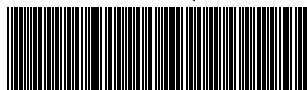

TOEPYEUOEC101

TOEPYEUOEC101

Revision: B <1>-0

May 2020

Published in Germany

11-9

YASKAWA