

# J1000

## Quick Start Guide

---

<b>1 Safety Instructions and General Warnings</b> .....	<b>4</b>
<b>2 Mechanical Installation</b> .....	<b>9</b>
<b>3 Electrical Installation</b> .....	<b>11</b>
<b>4 Keypad Operation</b> .....	<b>16</b>
<b>5 Start Up</b> .....	<b>18</b>
<b>6 Parameter Table</b> .....	<b>22</b>
<b>7 Troubleshooting</b> .....	<b>25</b>

## 1 Safety Instructions and General Warnings

Yaskawa Electric supplies component parts for use in a wide variety of industrial applications. The selection and application of Yaskawa products remain the responsibility of the equipment designer or end user. Yaskawa accepts no responsibility for the way its products are incorporated into the final system design. Under no circumstances should any Yaskawa product be incorporated into any product or design as the exclusive or sole safety control. Without exception, all controls should be designed to detect faults dynamically and fail safely under all circumstances. All products designed to incorporate a component part manufactured by Yaskawa must be supplied to the end user with appropriate warnings and instructions as to the safe use and operation of that part. Any warnings provided by Yaskawa must be promptly provided to the end user. Yaskawa offers an express warranty only as to the quality of its products in conforming to standards and specifications published in the manual. **NO OTHER WARRANTY, EXPRESS OR IMPLIED, IS OFFERED.** Yaskawa assumes no liability for any personal injury, property damage, losses, or claims arising from misapplication of its products.

### ◆ General Warnings

#### WARNING

- **Read and understand this manual before installing, operating or servicing this drive.**
- **All warnings, cautions, and instructions must be followed.**
- **All work must be performed by qualified personnel.**
- **The drive must be installed according to this manual and local codes.**

- **Heed the safety messages in this manual.**

The operating company is responsible for any injuries or equipment damage resulting from failure to heed the warnings in this manual.

The following conventions are used to indicate Safety messages in this manual:

#### DANGER

Indicates a hazardous situation, which, if not avoided, will result in death or serious injury.

#### WARNING

Indicates a hazardous situation, which, if not avoided, could result in death or serious injury.

#### CAUTION

Indicates a hazardous situation, which, if not avoided, could result in minor or moderate injury.

## NOTICE

Indicates a property damage message.



## ◆ Safety Warnings

### WARNING

#### Electrical Shock Hazard

- **Do not attempt to modify or alter the drive in any way not explained in this manual.**  
Failure to comply could result in death or serious injury.  
Yaskawa is not responsible for any modification of the product made by the user. This product must not be modified.
- **Do not touch any terminals before the capacitors have fully discharged.**  
Failure to comply could result in death or serious injury.  
Before wiring terminals, disconnect all power to the equipment. The internal capacitor remains charged even after the power supply is turned off. The charge indicator LED will extinguish when the DC bus voltage is below 50 Vdc. To prevent electric shock, wait at least one minute after all indicators are off and measure the DC bus voltage level to confirm safe level.
- **Do not allow unqualified personnel to use equipment.**  
Failure to comply could result in death or serious injury.  
Maintenance, inspection, and replacement of parts must be performed only by authorized personnel familiar with installation, adjustment, and maintenance of AC drives.
- **Do not remove covers or touch circuit boards while the power is on.**  
Failure to comply could result in death or serious injury.
- **Always ground the motor-side grounding terminal.**  
Improper equipment grounding could result in death or serious injury by contacting the motor case.
- **Do not perform work on the drive while wearing loose clothing, jewelry or without eye protection.**  
Failure to comply could result in death or serious injury.  
Remove all metal objects such as watches and rings, secure loose clothing, and wear eye protection before beginning work on the drive.
- **Never short the output circuits of the drive.**  
Do not short the output circuits of the drive. Failure to comply could result in death or serious injury.

# 1 Safety Instructions and General Warnings

 <b>WARNING</b>
<b>Sudden Movement Hazard</b>
<ul style="list-style-type: none"><li>• <b>System may start unexpectedly upon application of power, resulting in death or serious injury.</b> Clear all personnel from the drive, motor, and machine area before applying power. Secure covers, couplings, shaft keys, and machine loads before applying power to the drive.</li></ul>
<b>Fire Hazard</b>
<ul style="list-style-type: none"><li>• <b>Do not use an improper voltage source.</b> Failure to comply could result in death or serious injury by fire. Verify that the rated voltage of the drive matches the voltage of the incoming power supply before applying power.</li><li>• <b>Do not use improper combustible materials.</b> Failure to comply could result in death or serious injury by fire. Attach the drive to metal or other noncombustible material.</li><li>• <b>Do not connect AC line power to output terminals U, V, and W.</b> • <b>Make sure that the power supply lines are connected to main circuit input terminals R/L1, S/L2, T/L3 (or R/L1 and S/L2 for single-phase power).</b> Do not connect the AC power line to the output motor terminals of the drive. Failure to comply could result in death or serious injury by fire as a result of drive damage from line voltage application to output terminals.</li><li>• <b>Tighten all terminal screws to the specified tightening torque.</b> Loose electrical connections could result in death or serious injury by fire due to overheating of electrical connections.</li></ul>
 <b>CAUTION</b>
<b>Crush Hazard</b>
<ul style="list-style-type: none"><li>• <b>Do not carry the drive by the front cover.</b> Failure to comply may result in minor or moderate injury from the main body of the drive falling.</li></ul>
<b>Burn Hazard</b>
<ul style="list-style-type: none"><li>• <b>Do not touch the heatsink or braking resistor hardware until a powered-down cooling period has elapsed.</b></li></ul>

## NOTICE

### Equipment Hazard

- **Observe proper electrostatic discharge procedures (ESD) when handling the drive and circuit boards.**  
Failure to comply may result in ESD damage to the drive circuitry.
- **Never connect or disconnect the motor from the drive while the drive is outputting voltage.**  
Improper equipment sequencing could result in damage to the drive.
- **Do not perform a withstand voltage test on any part of the drive.**  
Failure to comply could result in damage to the sensitive devices within the drive.
- **Do not operate damaged equipment.**  
Failure to comply could result in further damage to the equipment.  
Do not connect or operate any equipment with visible damage or missing parts.
- **Install adequate branch circuit short circuit protection per applicable codes.**  
Failure to comply could result in damage to the drive.  
The drive is suitable for circuits capable of delivering not more than 100,000 RMS symmetrical Amperes, 240 Vac maximum (200 V Class) and 480 Vac maximum (400V Class).
- **Do not use unshielded cable for control wiring.**  
Failure to comply may cause electrical interference resulting in poor system performance. Use shielded twisted-pair wires and ground the shield to the ground terminal of the drive.
- **Do not allow unqualified personnel to use the product.**  
Failure to comply could result in damage to the drive or braking circuit.
- **Do not modify the drive circuitry.**  
Failure to comply could result in damage to the drive and will void warranty.  
Yaskawa is not responsible for modification of the product made by the user. This product must not be modified.
- **Check all the wiring to ensure that all connections are correct after installing the drive and connecting other devices.**  
Failure to comply could result in damage to the drive.
- **Do not connect unapproved LC or RC interference suppression filters, capacitors, or overvoltage protection devices to the output of the drive.**  
Using unapproved filters could result in damage to the drive or motor equipment.

# 1 Safety Instructions and General Warnings

---

## ◆ Precautions for CE Low Voltage Directive Compliance

---

This drive has been tested according to European standard EN61800-5-1: 2007, and it fully complies with the Low Voltage Directive. The following conditions must be met to maintain compliance when combining this drive with other devices:

Do not use drives in areas with pollution higher than severity 2 and overvoltage category 3 in accordance with IEC664.

Ground the neutral point of the main power supply for 400 V Class drives.

## ◆ Precautions for UL/cUL Standards Compliance

---

This drive is tested in accordance with UL standard UL508C and complies with UL requirements. The following conditions must be met to maintain compliance when using this drive in combination with other equipment:

Do not install the drive to an area greater than pollution severity 2 (UL standard).

Use UL-listed copper wires (rated at 75°C) and closed-loop connectors or CSA-certified ring connectors. For details refer to the instruction manual.

Wire low voltage wires with NEC Class 1 circuit conductors. Refer to national state or local codes for wiring. Use a class 2 (UL regulations) power supply for the control circuit terminal. For details refer to the instruction manual.

This drive has undergone the UL short-circuit test, which certifies that during a short circuit in the power supply the current flow will not rise above 30,000 amps maximum at 240 V for 200 V class drives and 480 V for 400 V class drives.

The drive internal motor overload protection is UL listed and in accordance with the NEC and CEC. The setup can be done using the parameters L1-01/02. For details refer to the technical manual.

## 2 Mechanical Installation

### ◆ Upon Receipt

Please perform the following tasks after receiving the drive:

- Inspect the drive for damage. If the drive appears damaged upon receipt, contact your supplier.
- Verify receipt of the correct model by checking the information on the nameplate. If you have received the wrong model contact your supplier.

### ◆ Installation Environment

For optimum performance life of the drive, install the drive in an environment that meets the conditions listed below.

Environment	Conditions
Installation Area	Indoors
Ambient Temperature	-10 °C to +50 °C When using an enclosure panel, install a cooling fan or air conditioner in the area to ensure that the air temperature inside the enclosure does not exceed the specified levels. Do not allow ice to develop on the drive.
Humidity	95% RH or less and free of condensation
Storage Temperature	-20 °C to +60 °C
Surrounding Area	Install the drive in an area free from: <ul style="list-style-type: none"> <li>• oil mist and dust</li> <li>• metal shavings, oil, water or other foreign materials</li> <li>• radioactive materials</li> <li>• combustible materials (e.g., wood)</li> <li>• harmful gases and liquids</li> <li>• excessive vibration</li> <li>• chlorides</li> <li>• direct sunlight</li> </ul>
Altitude	1000 m or less
Vibration	10 - 20 Hz at 9.8 m/s <sup>2</sup> , 20 - 55 Hz at 5.9 m/s <sup>2</sup>
Orientation	Install the drive vertically to maintain maximum cooling effects.

## 2 Mechanical Installation

### ◆ Installation Orientation and Spacing

Always install the drive in an upright position. Leave space around the unit for proper cooling as shown in the figure on the right.

**Note:** Several units can be installed closer together than shown in the figure by using “Side-by-Side” mounting. For details please refer to the instruction manual.

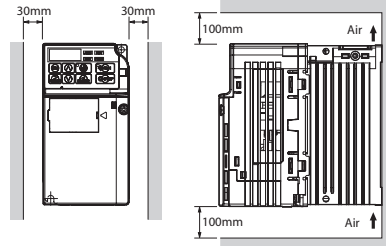

### ◆ Dimensions

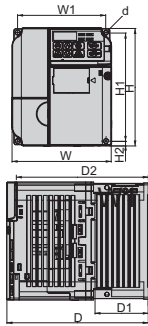

Model CIMR-JC□	Dimensions (mm)									Weight (kg)
	W	H	D	W1	H1	H2	D1	D2	d	
BA0001	68	128	76	56	118	5	6.5	67.5	M4	0.6
BA0002	68	128	76	56	118	5	6.5	67.5	M4	0.6
BA0003	68	128	118	56	118	5	38.5	109.5	M4	1.0
BA0006	108	128	137.5	96	118	5	58	129	M4	1.7
BA0010	108	128	154	96	118	5	58	145.5	M4	1.8
2A0001	68	128	76	56	118	5	6.5	67.5	M4	0.6
2A0002	68	128	76	56	118	5	6.5	67.5	M4	0.6
2A0004	68	128	108	56	118	5	38.5	99.5	M4	0.9
2A0006	68	128	128	56	118	5	58.5	119.5	M4	1.1
2A0010	108	128	129	96	118	5	58	120.5	M4	1.7
2A0012	108	128	137.5	96	118	5	58	129	M4	1.7
2A0020	140	128	143	128	118	5	65	134.5	M4	2.4
4A0001	108	128	81	96	118	5	10	72.5	M4	1.0
4A0002	108	128	99	96	118	5	28	90.5	M4	1.2
4A0004	108	128	137.5	96	118	5	58	129	M4	1.7
4A0005	108	128	154	96	118	5	58	145.5	M4	1.7
4A0007	108	128	154	96	118	5	58	145.5	M4	1.7
4A0009	108	128	154	96	118	5	58	145.5	M4	1.7
4A0011	140	128	143	128	118	5	65	134.5	M4	2.4



# 3 Electrical Installation

The figure below shows the main and control circuit wiring.

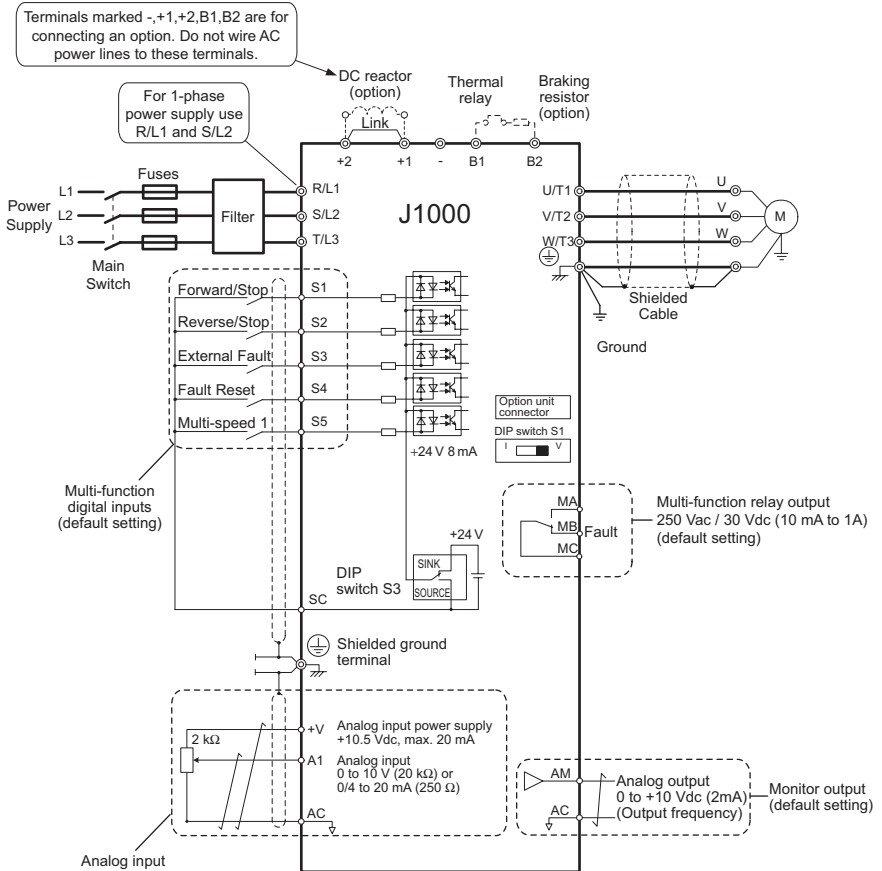

Symbols:

⊗ Use twisted pair cables

⊙ Indicates a main circuit terminal

⊗ Use shielded twisted pair cables

○ Indicates a control circuit terminal.

### 3 Electrical Installation

#### ◆ Wiring Specification

##### ■ Main Circuit

Use the fuses and line filters listed up in the table below when wiring the main circuit. Make sure not to exceed the given tightening torque values.

Model CIMR-JC□	EMC Filter Type	Main Fuse (Ferraz)	Recom. Motor cable [mm <sup>2</sup> ]	Main Circuit Terminal Sizes		
	Schaffner			R/L1,S/L2,T/L3, U/T1, V/T2,W/T3, -, +1, +2	B1, B2	GND
BA0001	FS23638-10-07	A6T15	2.5	M3.5	M3.5	M3.5
BA0002	FS23638-10-07	A6T20	2.5	M3.5	M3.5	M3.5
BA0003	FS23638-10-07	A6T20	2.5	M3.5	M3.5	M3.5
BA0006	FS23638-20-07	A6T40	2.5	M4	M4	M4
BA0010	FS23638-20-07	A6T40	4	M4	M4	M4
2A0001	FS23637-8-07	A6T10	2.5	M3.5	M3.5	M3.5
2A0002	FS23637-8-07	A6T10	2.5	M3.5	M3.5	M3.5
2A0004	FS23637-8-07	A6T15	2.5	M3.5	M3.5	M3.5
2A0006	FS23637-8-07	A6T20	2.5	M3.5	M3.5	M3.5
2A0010	FS23637-14-07	A6T25	2.5	M4	M4	M4
2A0012	FS23637-14-07	A6T30	4	M4	M4	M4
2A0020	FS23637-24-07	A6T40	6	M4	M4	M4
4A0001	FS23639-5-07	A6T10	2.5	M4	M4	M4
4A0002	FS23639-5-07	A6T10	2.5	M4	M4	M4
4A0004	FS23639-5-07	A6T20	2.5	M4	M4	M4
4A0005	FS23639-10-07	A6T25	2.5	M4	M4	M4
4A0007	FS23639-10-07	A6T25	2.5	M4	M4	M4
4A0009	FS23639-10-07	A6T25	2.5	M4	M4	M4
4A0011	FS23639-15-07	A6T30	2.5	M4	M4	M4

##### Tightening Torque Values

Tighten the main circuit terminals using the torque values provided by the table below.

Terminal Size	M3.5	M4
Tightening Torque [Nm]	0.8 to 1.0	1.2 to 1.5

##### ■ Control Circuit

Use wires within the specification listed below. For safe wiring use solid wires or flexible wires with ferrules. The stripping length or ferrule length should be 6 mm.

Terminal	Screw Size	Tightening Torque N·m	Bare Wire Terminal		Ferrule-Type Terminal	
			Applicable wire size mm <sup>2</sup>	Recomm. mm <sup>2</sup>	Applicable wire size mm <sup>2</sup>	Recomm. mm <sup>2</sup>
MA, MB, MC	M3	0.5 to 0.6	0.25 to 1.5	0.75	0.25 to 1.0	0.5
S1-S5, SC, +V, A1, AC, AM	M2	0.22 to 0.25	0.25 to 1.0	0.75	0.25 to 0.5	0.5

### ◆ EMC Filter Installation

This drive has been tested in accordance with European standards EN61800-3:2004. In order to comply to the EMC standards, wire the main circuit as described below.

1. Install an appropriate EMC noise filter to the input side. See the list above or refer to the instruction manual for details.
2. Place the drive and EMC noise filter in the same enclosure.
3. Use braided shield cable for the drive and motor wiring.
4. Remove any paint or dirt from ground connections for minimal ground impedance.
5. Install an AC reactor at drives smaller than 1 kW for compliance with the EN61000-3-2. Refer to the instruction manual or contact your supplier for details.

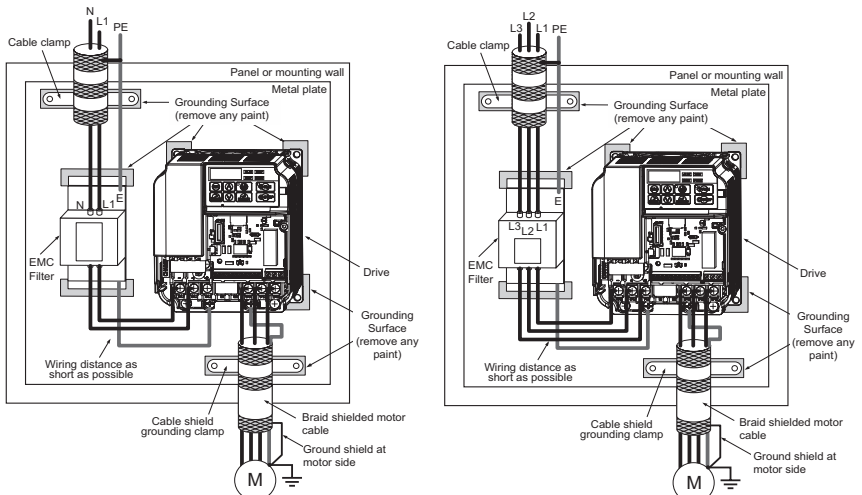

**EMC Standards Compliant Wiring of Single- and Three Phase Units**

### ◆ Main and Control Circuit Wiring

#### ■ Wiring the Main Circuit Input

Consider the following precautions for the main circuit input.

### 3 Electrical Installation

---

- Use only circuit breakers that have been designed specifically for drives.
- If using a ground fault circuit breaker, make sure that it can detect both DC and high frequency current.
- If using an input switch is used, make sure that the switch does not operate not more than once every 30 minutes.
- Use a DC reactor or AC reactor on the input side of the drive:
- To suppress harmonic current.
- To improve the power factor on the power supply side.
- When using an advancing capacitor switch.
- With a large capacity power supply transistor (over 600 kVA).

#### ■ Wiring the Main Circuit Output

Consider the following precautions for the output circuit wiring.

- Do not connect any other load than a 3 phase motor to the drives output.
- Never connect a power source to the drives output.
- Never short or ground the output terminals.
- Do not use phase correction capacitors.
- If using a contactor between the drive and motor, it should never be operated when the drive is outputting a voltage. Operating while there is voltage output can cause large peak currents, thus tripping the over current detection or damage the drive.

#### ■ Ground Connection

Take the following precautions when grounding the drive.

- Never share the ground wire with other devices such as welding machines, etc.
- Always use a ground wire, that complies with electrical equipment technical standards. Keep ground wires as short as possible. Leakage current is caused by the drive. Therefore, if the distance between the ground electrode and the ground terminal is too long, potential on the ground terminal of the drive will become unstable.
- When using more than one drive, do not to loop the ground wire.

#### ■ Control Circuit Wiring Precautions

Consider the following precautions for wiring the control circuits.

- Separate control circuit wiring from main circuit wiring and other high-power lines.
- Separate wiring for control circuit terminals MA, MB, MC (contact output) from wiring to other control circuit terminals.
- For external control power supply use a UL Listed Class 2 power supply.
- Use twisted-pair or shielded twisted-pair cables for control circuits to prevent operating faults.
- Ground the cable shields with the maximum contact area of the shield and ground.
- Cable shields should be grounded on both cable ends.

#### ■ Main Circuit Terminals

Terminal	Type	Function
R/L1, S/L2, T/L3	Main circuit power supply input	Connects line power to the drive. Drives with single-phase 200 V input power use terminals R/L1 and S/L2 only (T/L3 is not used).
U/T1, V/T2, W/T3	Drive output	Connects to the motor.
B1, B2	Braking resistor	For connecting a braking resistor.
+1, +2	DC reactor connection	Linked at shipment. Remove the link to install a DC choke.
+1, -	DC power supply input	For connecting a DC power supply.
 (2 terminals)	Ground Terminal	For 200 V class: Ground with 100 Ω or less For 400 V class: Ground with 10 Ω or less

#### ■ Control Circuit Terminals

The figure below shows the control circuit terminal arrangement.

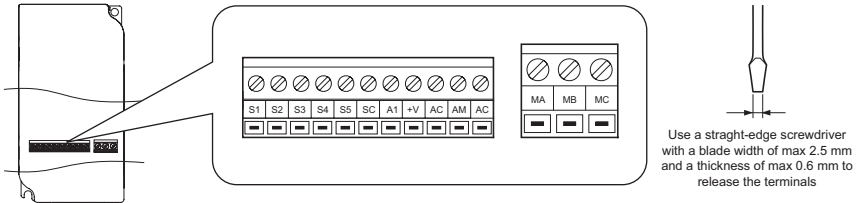

There are two DIP switches, S1 and S3, located on the control board

<b>SW1</b>	Switches analog input A1 between voltage and current input
<b>SW3</b>	Used to select sourcing (PNP)/sinking (NPN, default) mode for the digital inputs (PNP requires external 24 Vdc power supply)

#### ■ Control Circuit Terminal Functions

Type	No.	Terminal Name (Signal)	Function (Signal Level), Default Setting
Multi-Function Digital Inputs	S1 to S5	Multi-function digital input 1 to 5	Photocoupler inputs, 24 Vdc, 8 mA Note: Drive preset to sinking mode (NPN). When using source mode, set DIP switch S3 to “SOURCE” and use an external 24 Vdc (±10%) power supply.
	SC	Multi-function input common	Sequence common
Analog Input	A1	Analog input	0 to +10 Vdc (20 kΩ) resolution 1/1000 0/4 to 20 mA (250 Ω) resolution: 1/500
	+V	Analog input power supply	+10.5 V (max allowable current 20 mA)
	AC	Frequency reference common	0 V
Multi-Function Relay Output	MA	N.O. (fault)	Digital relay output 30 Vdc, 10 mA to 1 A 250 Vac, 10 mA to 1 A
	MB	N.C. output (fault)	
	MC	Digital output common	
Monitor Output	AM	Analog monitor output	0 to 10 Vdc (2 mA or less), Resolution: 1/256 (8 bit)
	AC	Monitor common	0 V

# 4 Keypad Operation

### ◆ LED Operator and Keys

The LED operator is used to program the drive, to start/stop it, and to display fault information. The LEDs indicate the drive status.



### ■ Keys and Functions

Display	Name	Function
	Data Display Area	Displays the frequency reference, parameter number, etc.
	ESC Key	Returns to the previous menu.
	RESET Key	Moves the cursor to the right. Resets a fault.
	RUN Key	Starts the drive in the LOCAL mode. The Run LED <ul style="list-style-type: none"> <li>• is on, when the drive is operating the motor.</li> <li>• flashes during deceleration to stop or when the frequency reference is 0.</li> <li>• flashes quickly the drive is disabled by a DI, the drive was stopped using a fast stop DI or a run command was active during power up.</li> </ul>
	Up Arrow Key	Scrolls up to select parameter numbers, setting values, etc.
	Down Arrow Key	Scrolls down to select parameter numbers, setting values, etc.
	STOP Key	Stops the drive.
	ENTER Key	Selects modes, parameters and is used to store settings.
	LO/RE Selection Key	Switches drive control between the operator (LOCAL) and the control circuit terminals (REMOTE). The LED is on when the drive is in the LOCAL mode (operation from keypad).
	ALM LED Light	Flashing: The drive is in an alarm state. On: The drive is in a fault state and the output is stopped.
	REV LED Light	On: The motor rotation direction is reverse. Off: The motor rotation direction is forward.
	DRV LED Light	On: The drive is ready to operate the motor. Off: The drive is in the Verify, Setup, Parameter Setting mode.
	FOUT LED Light	On: The output frequency is displayed on the data screen. Off: Anything else than the output frequency is displayed on the data screen.

## ◆ Menu Structure and Modes

The following illustration explains the operator keypad menu structure.

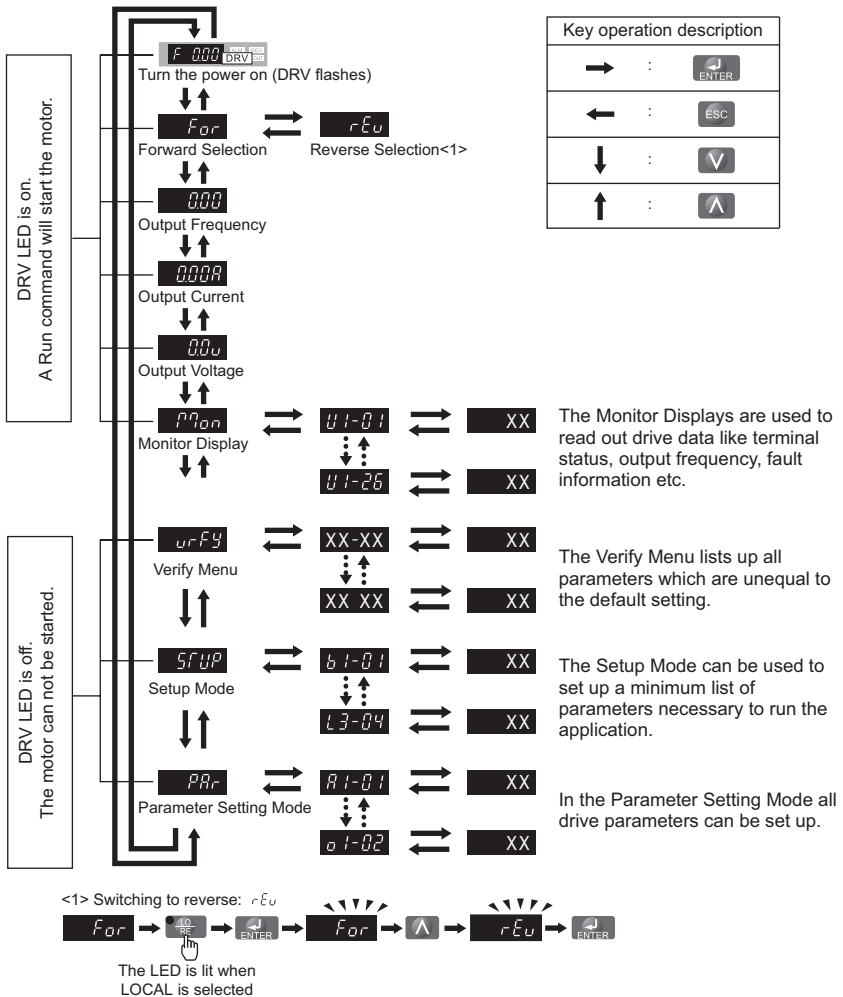

# 5 Start Up

### ◆ Drive Setup Procedure

The illustration below shows the basic setup procedure. Each step is explained more detailed on the following pages.

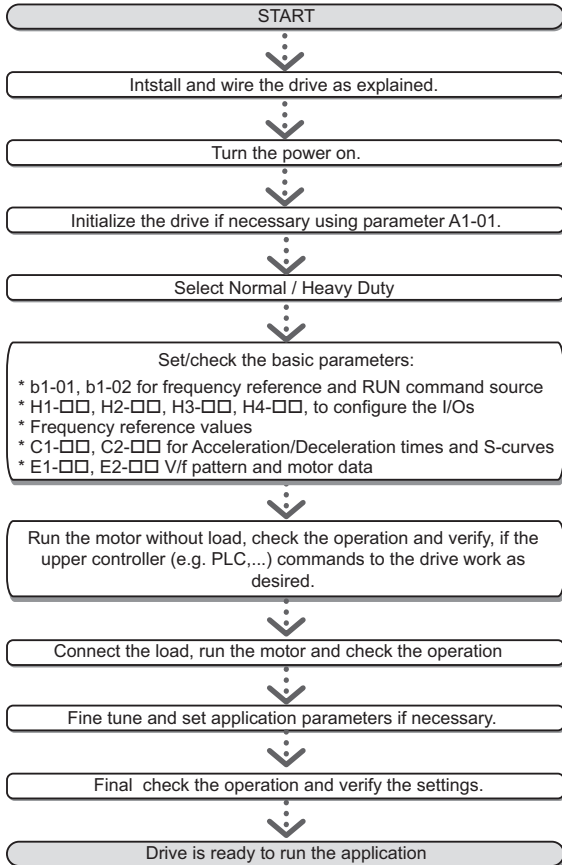



## ◆ Power On

Before turning on the power supply,

- Make sure all wires are connected properly.
- Make sure no screws, loose wire ends or tools are left in the drive.
- After turning the power on, the drive mode display should appear and no fault or alarm should be displayed.

## ◆ Normal / Heavy Duty Selection (C6-01)

The drive supports two ratings, Normal Duty and Heavy Duty. Both have different output current ratings (refer to the catalog or instruction manual). Set the Duty mode in accordance with the application.

Mode	Heavy Duty Ratings (HD)	Normal Duty Rating (ND)
C6-01	0	1
Application	Applications with a constant torque like extruders, conveyors and cranes. High overload capability might be needed.	Applications where the torque increases with the speed like fans or pumps. High overload tolerance is normally not needed.
Overload capability (OL2)	150% of drive rated current for 60 s	120% of drive rated current for 60 s
L3-02 Stall Prevention during Acceleration	150%	120%
L3-06 Stall Prevention during Run	150%	120%
Default carrier frequency	10 kHz, 8 kHz </>	Swing PMW

<1> Single-Phase AC200 V CIMR-JCBA0001 ~ BA0006 : 10kHz  
 Single-Phase AC200 V CIMR-JCBA0010 : 8kHz  
 Three-Phase AC200 V CIMR-JC2A0001 ~ 2A0006 : 10kHz  
 Three-Phase AC200 V CIMR-JC2A0008 ~ 2A0020 : 8kHz  
 Three-Phase AC400 V CIMR-JC4A0001 ~ 4A0011 : 8kHz

## ◆ Reference and Run Source

The drive has a LOCAL and a REMOTE mode. The LED in the LO/RE key indicates the drive status.

Status	Description	LO/RE LED
LOCAL	The Run/ Stop command and the frequency reference are entered at the operator keypad.	ON
REMOTE	The Run command source entered in parameter b1-02 and the frequency reference source entered in parameter b1-01 are used.	OFF

If the drive is operated in the REMOTE mode, make sure that the correct sources for the frequency reference and Run command are set in parameters b1-01/02 and that the drive is in the REMOTE mode.

### ◆ I/O Setup

---

#### ■ Multi-Function Digital Inputs (S1 to S5)

The function of each digital input can be assigned in the H1-□□ parameters. The default setting functions can be seen in the connection diagram on [page 11](#).

#### ■ Multi-Function Digital Output MA-MB-MC (H2-01)

The function of the digital output can be assigned in H2-01. The default setting is “Fault” (H2-01=E). The setting value of H2-01 consist of 3 digits, where the middle and right digit set the function and the left digit sets the output characteristics (0: Output as selected; 1: Inverse output).

#### ■ Analog Input A1 (H3-□□)

Analog Input A1 can be used to set the frequency reference when parameter b1-01=1. Use the H3-□□ parameters to adjust the gain and bias for the analog input. Select the input signal level in parameter H3-01.

**NOTICE!** *If the input signal level of input A1 is switched between voltage and current, make sure that DIP switch S1 is in the correct position and parameter H3-01 is set up correctly.*

#### ■ Analog Monitor Output (H4-□□)

Use the H4-□□ parameters to set up the output value of the analog monitor output and to adjust the output voltage levels. The default monitor value setting is “Output frequency”.

### ◆ Frequency Reference and Acceleration/ Deceleration Times

---

#### ■ Frequency Reference Setup(b1-01)

Set parameter b1-01 according to the frequency reference used.

b1-01	Reference source	Frequency reference input
0	Operator keypad	Set the frequency references in the d1-□□ parameters and used digital inputs to switch over between different reference values.
1	Analog input	Apply the frequency reference signal to terminal A1.
2	Serial Communications Option	RS232C or RS422/485 Memobus communication
3	Potentiometer Option	Potentiometer Option

### ■ Acceleration/ Deceleration Times and S-Curves

There are two sets of acceleration and deceleration times which can be set in the C1-□□ parameters. The default activated accel/ decel times are C1-01/02. Adjust these times to the appropriate values required by the application. If necessary S-curves can be activated in the C2-□□ parameters for softer accel/ decel start and end.

### ◆ Test Run

---

Perform the following steps to start up the machine after all parameter settings have been done.

1. Run the motor without load and check if all input, outputs and the sequence work as desired.
2. Connect the load to the motor.
3. Run the motor with load and make sure that there is no vibrations, hunting or motor stalling occurs.

After taking the steps listed above, the drive should be ready to run the application and perform the basic functions. For details about more advanced setup refer to the technical manual.

## 6 Parameter Table

### 6 Parameter Table

This parameter table shows the most important parameters. Default settings are bold type. Refer to the instruction manual for a complete list of parameters.

Par.	Name	Description
Initialization Parameters		
A1-01	Access Level Selection	Selects which parameters are accessible via the digital operator. 0:Operation only <b>2:Advanced Access Level</b>
A1-03	Initialize Parameters	Resets all parameters to default. (returns to 0 after initialization) 0000: No Initialize 2220: 2-Wire Initialization 3330: 3-Wire Initialization
Operation Mode Selection		
b1-01	Frequency Reference Selection	0:Operator - d1-□□ values <b>1:Analog input A1</b> 2:Serial Comm.option 3:Potentiometer Option
b1-02	Run Command Selection	0:Operator - RUN and STOP keys <b>1:Terminals - Digital Inputs</b> 2:Serial Comm.option
b1-03	Stopping Method Selection	Selects the stopping method when the run command is removed. <b>0:Ramp to Stop</b> 1:Coast to Stop
b1-04	Reverse Operation Selection	<b>0:Reverse enabled</b> 1:Reverse prohibited
b1-14	Phase Order Selection	Switches the output phase order. <b>0:Standard</b> 1:Switch phase order
DC Injection Braking		
b2-02	DC Injection Braking Current	Sets the DC Injection Braking current as a percentage of the drive rated current.

Par.	Name	Description
b2-03	DC Inj. Braking Time/DC Excitation Time at Start	Sets the time of DC Injection Braking at start in units of 0.01 seconds. Disabled when set to 0.00 seconds.
b2-04	DC Inj. Braking Time at Stop	Sets the DC Injection Braking time at stop. Disabled when set to 0.00 seconds.
Acceleration/ Deceleration		
C1-01	Accel Time 1	Sets the acceleration time 1 from 0 to the max. output frequency.
C1-02	Decel Time 1	Sets the deceleration time 1 from the max. output frequency to 0.
C2-01	S-Curve 1	S-curve at acceleration start.
C2-02	S-Curve 2	S-curve at acceleration end.
C2-03	S-Curve 3	S-curve at deceleration start.
C2-04	S-Curve 4	S-curve at deceleration end.
Slip Compensation		
C3-01	Slip Compensation Gain	<ul style="list-style-type: none"> <li>• Increase if the speed is lower than the frequency reference</li> <li>• Decrease if the speed is higher than the frequency reference.</li> </ul>
C3-02	Slip Compensation Delay Time	<ul style="list-style-type: none"> <li>• Decrease the setting when the slip compensation is too slow.</li> <li>• Increase the setting when the speed is not stable.</li> </ul>
Torque Compensation		
C4-01	Torque Compensation Gain	<ul style="list-style-type: none"> <li>• Increase this setting when the torque response is slow</li> <li>• Decrease this setting when speed/torque oscillations occur.</li> </ul>
Duty Mode and Carrier Frequency		
C6-01	Normal/ Heavy Duty Selection	<b>0: Heavy Duty (HD) Constant torque applications</b> 1:Normal Duty (ND) Variable torque application

## 6 Parameter Table

Par.	Name	Description
C6-02	Carrier Frequency Selection	1:2.0 kHz
		2:5.0 kHz
		3:8.0 kHz
		4:10.0 kHz
		5:12.5 kHz
		6:15.0 kHz
		7:Swing PWM
		F: User defined
Frequency References		
d1-01 to d1-08	Frequency Reference 1 to 8	Set the multi-speed references 1 to 8
d1-17	Jog Speed	Jog speed
V/f Pattern		
E1-01	Input Voltage Setting	Input Voltage
E1-04	Max. Output Freq.	For a linear V/f characteristics, set the same values for E1-07 and E1-09. In this case, the setting for E1-08 will be disregarded. Ensure that the four frequencies are set according to these rules or OPE10 fault will occur:  E1-04 ≥ E1-06 ≥ E1-07 ≥ E1-09
E1-05	Max. Output Voltage	
E1-06	Base Frequency	
E1-07	Middle Output Freq.	
E1-08	Mid. Output Voltage	
E1-09	Min. Output Freq.	
E1-10	Min. Output Voltage	
Motor Data		
E2-01	Motor Rated Current	Motor rated current in Ampere.
E2-02	Motor Rated Slip	Motor rated slip in hertz (Hz).

Par.	Name	Description
E2-03	Motor No-Load Current	Magnetizing current in Ampere.
E2-05	Motor Line-to-Line Resistance	Sets the phase-to-phase motor resistance in ohms.
Digital Input Settings		
H1-01 to H1-05	DI S1 to S5 Function Selection	Selects the function of terminals S1 to S5.
A list of the major functions can be found at the table end.		
Digital Output Settings		
H2-01	DO MA/MB Function	Set the function for the relay output MA-MB-MC.
Major functions are listed at the end of the table.		
Analog Input Setting		
H3-01	A1 Signal Level Sel.	<b>0:0 to +10 V (neg. input is zeroed)</b>
		1:0 to +10 V (bipolar input)
		2:4~20mA (9 bit input)
		3:0~20mA
H3-03	A1 Gain	Sets the input value in % at 10 V/20 mA analog input.
H3-04	A1 Bias	Sets the input value in % at 0 V/0 mA/4 mA analog input.
Analog Input Setting		
H4-01	AM Monitor Selection	Enter value equal to U1-□□ monitor values. Example: Enter "103" for U1-03.
H4-02	AM Gain	Sets terminal AM output voltage equal to 100% monitor value.
H4-03	AM Bias	Sets terminal AM output voltage equal to 0% monitor value.
Motor Overheat Protection		
L1-01	Motor Overload Prot. Sel.	Sets the motor overload protection. 0:Disabled <b>1:Standard fan cooled motor</b> 2:Standard blower cooled motor
L1-02	Motor Overload Prot. Time	Sets the motor overload protection time in min. Normally no change is necessary.

## 6 Parameter Table

Par.	Name	Description
Stall Prevention		
L3-01	Stall Prevention Selection during Acceleration	0: Disabled - Motor accelerates at active acceleration rate and may stall with too heavy load or too short accel time. <b>1: General Purpose - Hold acceleration when current is above L3-02.</b>
L3-02	Stall Prev. Level during Accel.	Sets the current level for stall prevention during acceleration.
L3-04	Stall Prev. Selection during Decel.	0: Disabled - Deceleration as set. OV might occur. <b>1: General Purpose - Deceleration is hold if DC bus voltage rises high.</b> 4: Overexcitation Deceleration
L3-05	Stall Prev. Selection during Run	0: Disabled - Motor stall or overload might occur. <b>1: Decel Time 1 - Reduce speed using C1-02.</b> 2: Decel Time 2
L3-06	Stall Prev. Level during Run	Sets the current level at which stall prevention during run starts to operate.

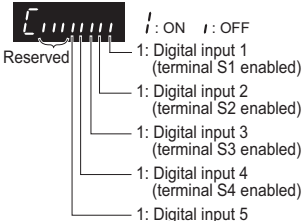
Monitor	Description
U1-01	Frequency Reference (Hz)
U1-02	Output Frequency (Hz)
U1-03	Output Current (A)
U1-06	Output Voltage Reference (Vac)
U1-07	DC Bus Voltage (Vdc)
U1-10	Input Terminal Status 

Monitor	Description
U1-11	Output Terminal Status 
U1-13	Terminal A1 input level
Fault Trace	
U2-01	Current Fault
U2-02	Previous Fault

DI/DO Sel.	Description
Digital Input Function Selections	
3	Multi-step speed reference 1
4	Multi-step speed reference 2
5	Multi-step speed reference 3
6	Jog frequency command (higher priority than multi-step speed reference)
7	Accel/decel time selection
F	Not used (Set when a terminal is not used)
14	Fault reset (Reset when turned ON)
20 to 2F	External fault; Input mode: N.O. contact / N.C. contact, Detection mode: Normal/during operation
Digital Output Function Selections	
0	During Run (ON: run command is ON or voltage is being output)
1	Zero Speed
2	Speed Agree
6	Drive Ready
E	Fault
F	Not used
10	Minor fault (Alarm) (ON: Alarm displayed)

## 7 Troubleshooting

### ◆ General Fault and Alarms

Faults and alarms indicate problems in the drive or in the machine.

An alarm is indicated by a code on the data display and the flashing ALM LED. The drive output is not necessarily switched off.

A fault is indicated by a code on the data display and the ALM LED is on. The drive output is always switched off immediately and the motor coast to stop.

To remove an alarm or reset a fault, trace the cause, remove it and reset the drive by pushing the Reset key on the operator or cycling the power supply.

This lists up the most important alarms and faults only. Please refer to the instruction manual for a complete list.

LED Display	ALM	FLT	Cause
Base Block <i>bb</i>	○		The software base block function is assigned to one of the digital inputs and the input is off. The drive does not accept Run commands.
Control Circuit Fault <i>[PF02 to PF24]</i>		○	There is a problem in the drive's control circuit.
Cannot Reset <i>[r5f]</i>	○		Fault reset was input when a run command was active.
Option External Fault <i>EF0</i>	○	○	An external fault was tripped by the upper controller via an option unit.
External Fault <i>EF</i>	○		A forward and reverse command were input simultaneously for longer than 500 ms. This alarm stops a running motor.
External Faults <i>EF1 to EF5</i>		○	<ul style="list-style-type: none"> <li>• An external fault was triggered by an external device via one of the digital inputs S1 to S5.</li> <li>• The digital inputs are set up incorrectly.</li> </ul>
Output Phase Loss <i>PF</i>		○	<ul style="list-style-type: none"> <li>• Output cable is disconnected or the motor winding is damaged.</li> <li>• Loose wires at the drive output.</li> <li>• Motor is too small (less than 5% of drive current).</li> </ul>
Overcurrent <i>OL</i>		○	<ul style="list-style-type: none"> <li>• Short circuit or ground fault on the drive output side</li> <li>• The load is too heavy.</li> <li>• The accel./decel. times are too short.</li> <li>• Wrong motor data or V/f pattern settings.</li> <li>• A magnetic contactor was switched at the output.</li> </ul>

## 7 Troubleshooting

LED Display	ALM	FLT	Cause
Heatsink Overheat □H or □H I	○	○	<ul style="list-style-type: none"> <li>Surrounding temperature is too high.</li> <li>The cooling fan has stopped.</li> <li>The heatsink is dirty.</li> <li>The airflow to the heatsink is restricted.</li> </ul>
Motor Overload □L I		○	<ul style="list-style-type: none"> <li>The motor load is too heavy.</li> <li>The motor is operated at low speed with heavy load.</li> <li>Cycle times of accel./ decel. are too short.</li> <li>Incorrect motor rated current has been set.</li> </ul>
Drive Overload □L 2		○	<ul style="list-style-type: none"> <li>The load is too heavy.</li> <li>The drive capacity is too small.</li> <li>Too much torque at low speed.</li> </ul>
DC Overvoltage □U	○	○	<ul style="list-style-type: none"> <li>DC bus voltage rose too high.</li> <li>The deceleration time is too short.</li> <li>Stall prevention is disabled.</li> <li>Braking chopper/ resistor broken</li> <li>Too high input voltage.</li> </ul>
Input Phase Loss LF		○	<ul style="list-style-type: none"> <li>Input voltage drop or phase imbalance.</li> <li>One of the input phase is lost.</li> <li>Loose wires at the drive input.</li> </ul>
DC Undervoltage UU or UU I	○	○	<ul style="list-style-type: none"> <li>The voltage in the DC bus fell below the undervoltage detection level.</li> <li>The power supply failed or one input phase has been lost.</li> <li>The power supply is too weak.</li> </ul>
DC Charge Circuit Fault UU 3		○	<ul style="list-style-type: none"> <li>The charge circuit for the DC bus is broken.</li> </ul>



## ◆ Operator Programing Errors

An Operator Programming Error (OPE) occurs when an inapplicable parameter is set or an individual parameter setting is inappropriate. This monitor will display the parameter that is causing the OPE error.

LED Operator Display	Cause	Corrective Action
oPE01 oPE01	Drive capacity and value set to o2-04 do not match.	Correct the value set to o2-04.
oPE02 oPE02	Parameters were set outside the allowable setting range.	Set parameters to the proper values.
oPE03 oPE03	A contradictory setting is assigned to multi-function contact inputs H1-01 through to H1-05. <ul style="list-style-type: none"> <li>• The same function is assigned to two inputs (this excludes “External fault” and “Not used”)</li> <li>• Input functions which require the setting of other input functions were set alone.</li> <li>• Input functions that are not allowed to be used simultaneously have been set.</li> </ul>	<ul style="list-style-type: none"> <li>• Fix any incorrect settings.</li> <li>• Refer to the instruction manual for more details.</li> </ul>
oPE05 oPE05	No option unit is installed and one of the following is true: <ul style="list-style-type: none"> <li>• b1-01=2 or 3</li> <li>• b1-02=2</li> </ul>	<ul style="list-style-type: none"> <li>• Install the required option unit.</li> <li>• Correct the values set to b1-01 and b1-02.</li> </ul>
oPE10 oPE10	The V/f pattern setting is incorrect.	<ul style="list-style-type: none"> <li>• Check the V/f pattern settings.</li> <li>• Refer to the instruction manual for more details.</li> </ul>

## 7 Troubleshooting

---

# Revision History

The revision dates and numbers of the revised manuals are given on the bottom of the back cover.

MANUAL NO. TOEP C710606 27A

Published in Japan January 2008 08-1

└─ Date of original publication  
└─ Date of publication

<b>Date of Publication</b>	<b>Rev. No.</b>	<b>Section</b>	<b>Revised Contents</b>
January 2008	-		First edition